



"Excellence is not a singular act. but a habit. You are what you do repeatedly."

KOLEKSI SOALAN

FIZIK SPM

SPM KSSM: 2021 - 2023



NEW
UPDATE

SPM 2024

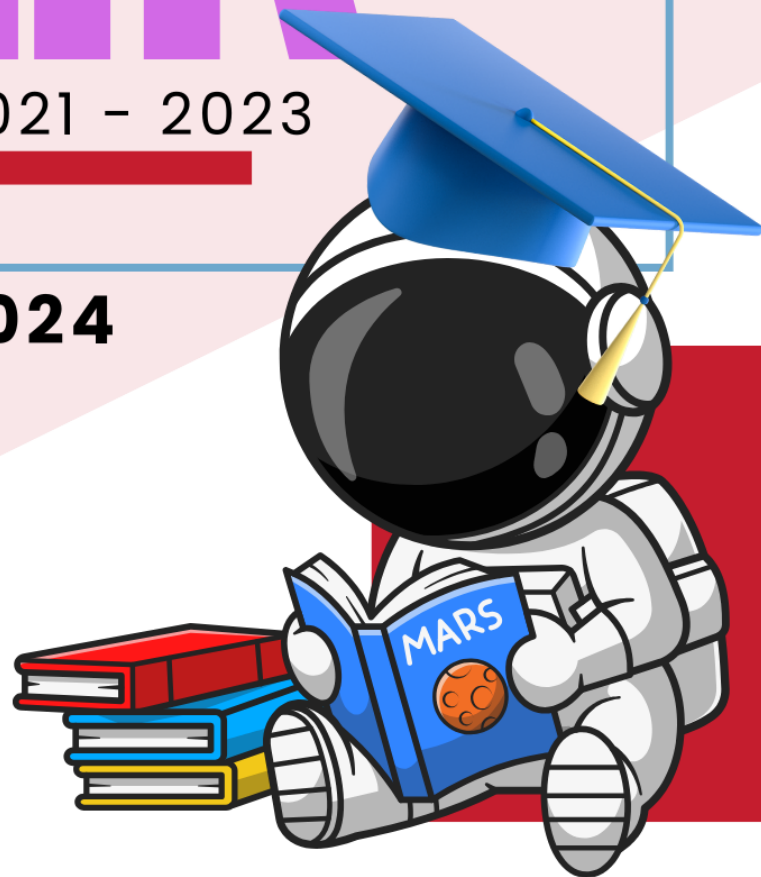

SOALAN DISUSUN
MENGIKUT BAB F4 & F5

"Ilmu itu didapati dengan lidah
yang gemar bertanya
dan akal yang suka berfikir"
-Abdullah Ibnu Abbas-

TIDAK DIBENARKAN JUAL BELI



PHYSICS

Maklumat berikut mungkin berfaedah. Simbol-simbol mempunyai makna yang biasa.
The following information may be useful. The symbols have their usual meaning.

1. FORCE AND MOTION I

$$a = \frac{v-u}{t}$$

$$s = \frac{1}{2}(u+v)t$$

$$s = ut + \frac{1}{2}at^2$$

$$v^2 = u^2 + 2as$$

$$\text{Momentum} = mv$$

$$F = ma$$

$$F = \frac{mv-mu}{t}$$

$$Ek = \frac{1}{2}mv^2$$

$$Ep = mgh$$

2. GRAVITATION

$$F = \frac{Gm_1m_2}{r^2}$$

$$g = \frac{GM}{r^2}$$

$$F = \frac{mv^2}{r}$$

$$a = \frac{v^2}{r}$$

$$v = \sqrt{\frac{GM}{r}}$$

$$v = \frac{2\pi r}{T}$$

$$U = -\frac{Gm_1m_2}{r}$$

$$v = \sqrt{\frac{2GM}{r}}$$

$$T^2 = \frac{4\pi^2 r^3}{GM}$$

$$\frac{T_1^2}{T_2^2} = \frac{r_1^3}{r_2^3}$$

$$g = 9.81 \text{ ms}^{-2} @ \text{ N kg}^{-1}$$

$$G = 6.67 \times 10^{-11} \text{ N m}^2 \text{ kg}^{-2}$$

3. HEAT

$$Q = mc\theta$$

$$Q = ml$$

$$Q = Pt$$

$$P_1V_1 = P_2V_2$$

$$\frac{V_1}{T_1} = \frac{V_2}{T_2}$$

$$\frac{P_1}{T_1} = \frac{P_2}{T_2}$$

4. WAVES

$$f = \frac{1}{T}$$

$$v = f\lambda$$

$$\lambda = \frac{ax}{D}$$

5. LIGHT & OPTICS

$$n = \frac{c}{v}$$

$$n = \frac{\sin i}{\sin r}$$

$$n = \frac{1}{\sin C}$$

$$n = \frac{H}{h}$$

$$n_1 \sin \theta_1 = n_2 \sin \theta_2$$

$$\frac{1}{f} = \frac{1}{u} + \frac{1}{v}$$

$$\text{Linear magnification, } m = \frac{v}{u}$$

The **KEY** to **SUCCESS** is to start **BEFORE** you are **READY**

6. FORCE AND MOTION II

$$F = kx$$

$$E = \frac{1}{2} Fx$$

$$E = \frac{1}{2} kx^2$$

7. PRESSURE

$$P = \frac{F}{A}$$

$$P = h\rho g$$

$$\rho = \frac{m}{V}$$

$$\frac{F_1}{A_1} = \frac{F_2}{A_2}$$

$$A_1 h_1 = A_2 h_2$$

$$F_b = \rho V g$$

8. ELECTRICITY

$$E = \frac{F}{Q}$$

$$I = \frac{Q}{t}$$

$$V = \frac{E}{Q}$$

$$V = IR$$

$$R = \frac{\rho l}{A}$$

$$E = V + Ir$$

$$P = IV$$

$$P = \frac{V^2}{R}$$

$$P = I^2 R$$

$$P = \frac{E}{t}$$

$$E = \frac{F}{d}$$

9. ELECTROMAGNETISME

$$\frac{V_S}{V_P} = \frac{N_S}{N_P}$$

$$n = \frac{\text{Output power}}{\text{Input power}} \times 100\%$$

10. ELECTRONIC

$$E = eV$$

$$E = \frac{1}{2} mv^2$$

$$\beta = \frac{I_C}{I_B}$$

$$V_1 = \left(\frac{R_1}{R_1 + R_2} \right) V$$

$$V_2 = \left(\frac{R_2}{R_1 + R_2} \right) V$$

$$e = 1.66 \times 10^{-19} \text{ C}$$

11. PHYSICS NUCLEAR

$$N = \left(\frac{1}{2} \right)^n N_0$$

$$E = mc^2$$

$$c = 3.00 \times 10^8 \text{ m s}^{-1}$$

$$1 \text{ a.m.u.} = 1.66 \times 10^{-27} \text{ kg}$$

12. QUANTUM PHYSICS

$$E = hf$$

$$f = \frac{c}{\lambda}$$

$$\lambda = \frac{h}{p}$$

$$\lambda = \frac{h}{mv}$$

$$E = \frac{hc}{\lambda}$$

$$P = nhf$$

$$hf = W + \frac{1}{2} mv^2_{\text{maks}}$$

$$W = hf_0$$

$$h = 6.63 \times 10^{-34} \text{ J s}$$

$$e = 1.66 \times 10^{-19} \text{ C}$$



F4 BAB 1: PENGUKURAN

SPM 2024

- 1 (a) Data penyiasatan saintifik bagi hubungan antara halaju dengan masa boleh ditafsir dengan memplot graf. Rajah 1.1 dan Rajah 1.2 menunjukkan dua graf halaju melawan masa.
Scientific investigation data of the relationship between velocity and time can be interpreted by plotting graphs. Diagrams 1.1 and 1.2 show two graphs of velocity against time.

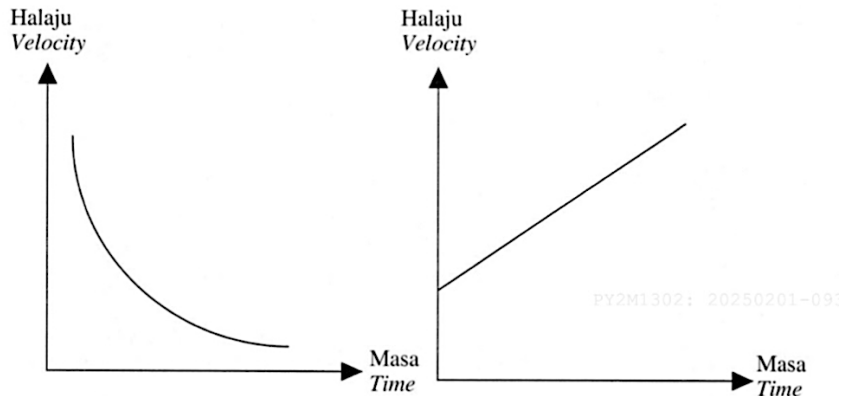

Rajah 1.1 / Diagram 1.1

Rajah 1.2 / Diagram 1.2

Nyatakan hubungan antara halaju dengan masa bagi,
State the relationship between velocity and time for,

- (i) Rajah 1.1 / Diagram 1.1:
- (ii) Rajah 1.2 / Diagram 1.2:
 [2 markah / marks]
- (b) Rajah 1.3 menunjukkan maklumat perjalanan seorang lelaki dari bandar P ke bandar Q.
Diagram 1.3 shows the travel information of a man from city P to city Q.

Jarak / Distance:	500 km
Masa / Time:	5 jam / 5 hours
Halaju purata / Average velocity:	90 kmj ⁻¹ / 90 kmh ⁻¹

Rajah 1.3 / Diagram 1.3

Berdasarkan Rajah 1.3, kenal pasti:
Based on Diagram 1.3, identify:

- (i) Kuantiti skalar / *Scalar quantity*:
- (ii) Kuantiti vektor / *Vector quantity*:

[2 markah / marks]

TOTAL 4 marks

F4 BAB 2: DAYA & GERAKAN 1

SPM 2021 (SET 2)

- 7 Rajah 7.1 menunjukkan tukul berjisim 0.8 kg digunakan untuk mengetuk paku. Paku itu bergerak masuk ke dalam kayu disebabkan oleh daya impuls.
Diagram 7.1 shows a 0.8 kg hammer used to hit the nail. The nail moves inside the wood because of impulsive force.

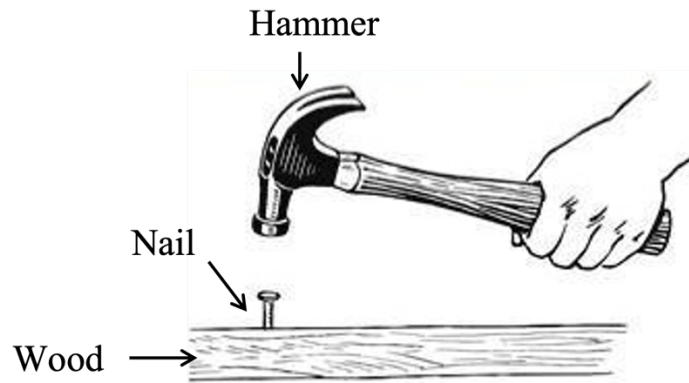

Diagram 7.1

- (a) Apakah maksud daya impuls?
What is the meaning of impulsive force?
-
- [1 mark]
- (b) (i) Jika kelajuan tukul semasa mengetuk paku adalah 20 m s^{-1} dan kemudian berhenti dalam masa 0.05 s, hitung daya impuls yang dikenakan ke atas paku tersebut.
If the velocity of the hammer while hitting and stopped in 0.05 s, calculate the impulsive force acted on the nail.
- [2 marks]
- (ii) Apakah yang berlaku kepada daya impuls jika kelajuan tukul semasa mengetuk paku bertambah?
What happen to the impulsive force if the speed of hammering increases when it hit the nail?
-

[1 mark]

- (c) Rajah 7.2 menunjukkan proses pemasangan jubin lantai. Gandin digunakan untuk mengetuk permukaan jubin tanpa memecahkannya.
 Diagram 7.2 shows the process of installing floor tiles. Mallet is used to knocking the tile surface without breaking it.

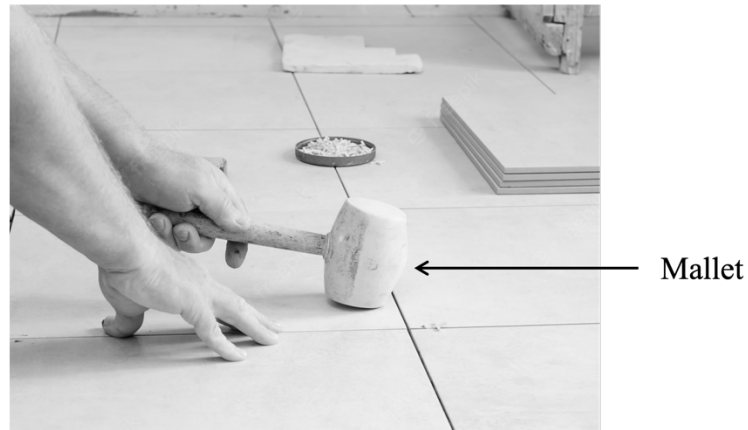

Diagram 7.2

Rajah 7.3 menunjukkan ciri-ciri tiga ganding X, Y dan Z.
 Diagram 7.3 shows the characteristics of three mallet X, Y and Z.

<p>Mallet X</p>		<p>← Rubber</p>
<p>Mallet Y</p>		<p>← Rubber</p>
<p>Mallet Z</p>		<p>← Iron</p>

Diagram 7.3

Berdasarkan Rajah 7.3, nyatakan ciri-ciri gandin yang sesuai untuk memasang jubin tersebut. Berikan sebab untuk kesesuaian ciri-ciri tersebut.

Based on Diagram 7.3, state the suitable characteristics of the mallet used to install the floor tiles. Give reasons for the suitability of the characteristics.

- (i) Bahan kepala gandin
Head material of the mallet

..... [1 mark]

Sebab
Reason

..... [1 mark]

- (ii) Jenis pemegang
Type of handle

..... [1 mark]

Sebab
Reason

..... [1 mark]

- (iii) Berdasarkan jawapan anda di 7(c)(i) dan 7(c)(ii), pilih gandin yang paling sesuai digunakan untuk memasang jubin lantai tanpa memecahkannya.
Based on the answer in 7(c)(i) and 7(c)(ii), choose the most suitable mallet that can be used to install the floor tiles without breaking it.

..... [1 mark]

TOTAL 9 marks

SPM 2021 (SET 2)

- 9 Rajah 9.1 menunjukkan seorang pemain softball meneruskan hayunan batang pemukul selepas bola dipukul untuk meningkatkan impuls.

Diagram 9.1 shows a softball player continuing to swing the bat after the ball is hit to increase impulse.

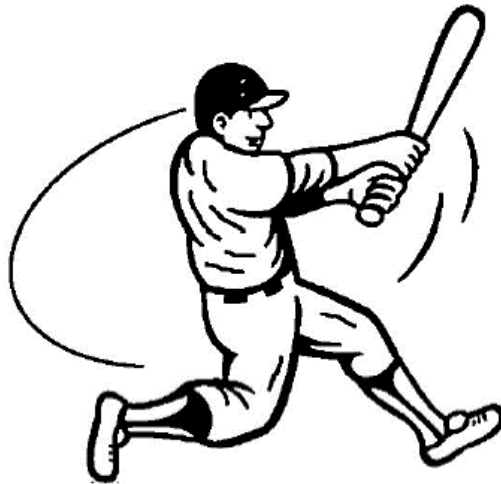

Diagram 9.1

- (a) Apakah maksud impuls?
What is meant by impulse?

[1 mark]

- (b) Terangkan bagaimana teknik ikut lajak pada Rajah 9.1 dapat meningkatkan impuls.
Explain how follow through technique in Diagram 9.1 can increase the impulse.

[4 marks]

- (c) Rajah 9.2 menunjukkan batang pemukul softball.
Diagram 9.2 shows a softball bat.

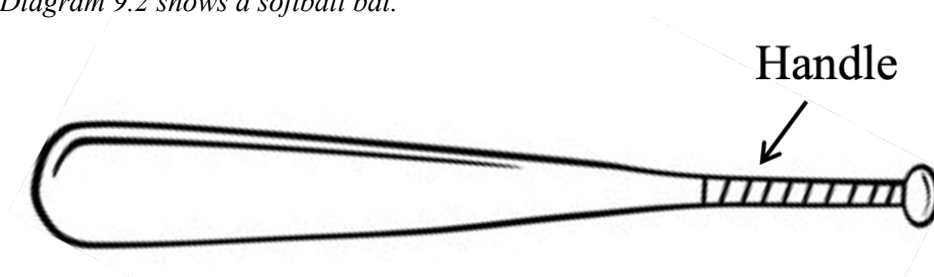

Diagram 9.2

Jadual 9 menunjukkan empat jenis batang pemukul P, Q, R dan S.
Table 9 shows four types of softball bat P, Q, R and S.

Batang pemukul <i>Bat</i>	Jisim (kg) <i>Mass (kg)</i>	Bahan <i>Material</i>	Bahan tambahan pada pemegang <i>Additional material on the handle</i>	Panjang batang pemukul (cm) <i>Length of softball bat (cm)</i>
P	0.6	Kayu <i>Wood</i>	Ada grip <i>With Grip</i>	80
Q	0.8	Kayu <i>Wood</i>	Tiada grip <i>Whitout grip</i>	75
R	1.0	Logam <i>Metal</i>	Ada grip <i>With Grip</i>	85
S	1.2	Logam <i>Metal</i>	Tiada grip <i>Whitout grip</i>	70

Table 9

Anda dikehendaki menentukan jenis batang pemukul yang dapat menghasilkan pukulan bola yang paling jauh. Kaji spesifikasi keempat-empat jenis batang pemukul berdasarkan aspek yang diberi. Terangkan kesesuaian setiap spesifikasi dan seterusnya tentukan jenis batang pemukul yang paling sesuai. Beri sebab untuk pilihan anda.

You are required to determine the type of bat that can make the farthest shot of the ball. Study the specifications of the four types of bat based on the aspects given. Explain the suitability of each specification and then determine the most suitable type of bat. Give reasons for your answers.

[10 marks]

- (d) Pemain softball memukul dan mengenakan daya 50 N ke atas bola berjisim 0.2 kg sedang bergerak dengan halaju 72 km h^{-1} . Masa sentuhan bola dengan batang pemukul ialah 0.2 saat.

A softball player hit and exerted 50 N force on a ball with a mass of 0.2 kg which is moving at a velocity of 72 km h^{-1} . Time contact of the ball with the bat is 0.2 second.

- (i) Hitung impuls yang dialami oleh bola itu.
Calculate the impulse experienced by the ball.

[2 marks]

- (ii) Selepas bola dipukul, bola melantun ke arah bertentangan. Hitung halaju lantunan bola dalam unit Sistem Antarabangsa (SI).
After the ball is hit, the ball is bounced in the opposite direction. Calculate the bounce velocity of the ball in International System of Units (SI).

[3 marks]

TOTAL 20 marks

SPM 2023

- 9 Rajah 9.1 menunjukkan seorang pekerja pembinaan sedang mengendalikan mesin penghentak cerucuk di kawasan tapak pembinaan.

Daya dihasilkan apabila penghentak cerucuk menghentam cerucuk.

Diagram 9.1 shows a construction worker handling a pile driver machine at a construction area.

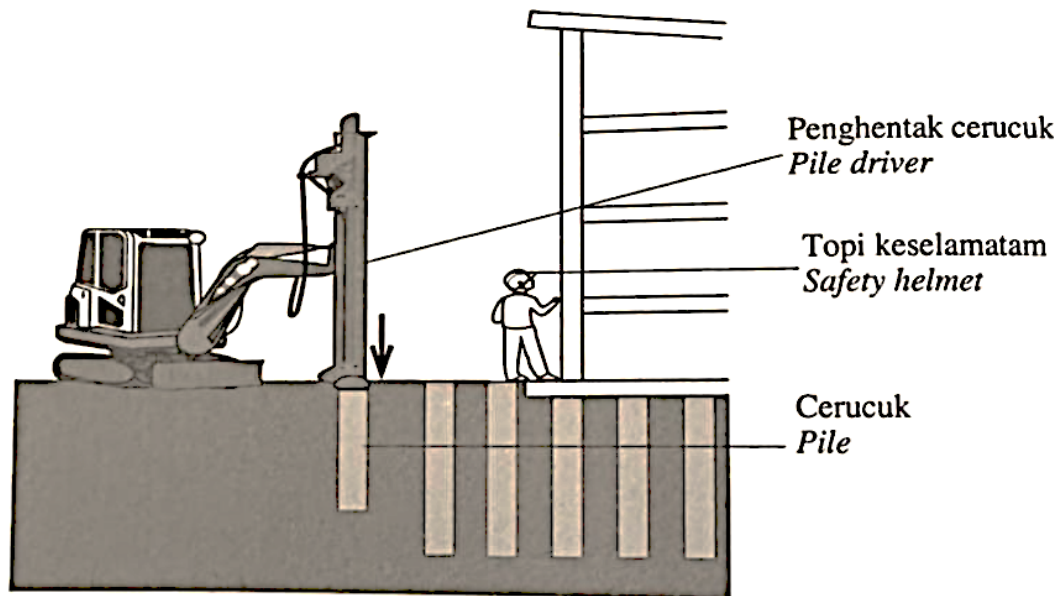

The force is produced when the pile driver hits the pile.



Rajah 9.1 / Diagram 9.1

- (a) Namakan daya yang bertindak ke atas cerucuk dalam Rajah 9.1.
Name the force acting on the pile in Diagram 9.1.
- [1 markah / mark]
- (b) Pekerja di kawasan pembinaan perlu memakai topi keselamatan.
Terangkan ciri-ciri topi keselamatan yang sesuai untuk melindungi kepala pekerja daripada kecederaan yang serius.
Workers in construction areas must wear safety helmets.
Explain what the appropriate safety helmet features are to protect the worker's head from serious injury.
- [4 markah / marks]

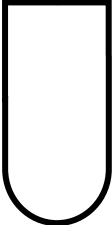
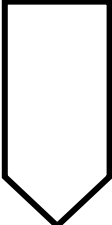
- (c) Jadual 9 menunjukkan empat sistem cerucuk, P, Q, R dan S yang digunakan di kawasan tapak pembinaan.
Table 9 shows four pile systems, P, Q, R and S which are used in the construction site area.

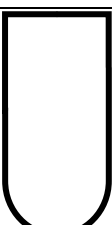
Sistem cerucuk <i>Piling system</i>	Ketinggian penghentak <i>Height of the pile driver</i>	Jisim cerucuk <i>Mass of the pile driver</i>	Bahan cerucuk <i>Material of pile</i>	Bentuk hujung cerucuk <i>Shape of the tip of the pile</i>
P	8 m	200 kg	Besi <i>Iron</i>	
Q	12 m	150 kg	Besi <i>Iron</i>	
R	12 m	200 kg	Konkrit <i>Concrete</i>	
S	8 m	100 kg	Konkrit <i>Concrete</i>	

Jadual 9 / Table 9

Kaji setiap ciri sistem cerucuk, P, Q, R dan S dan terangkan kesesuaian setiap ciri. Tentukan sistem cerucuk yang paling sesuai untuk digunakan dalam pembinaan. Berikan sebab untuk pilihan anda.

Study each characteristic of P, Q, R and S piling systems and explain the suitability for each characteristic.

Determine the most suitable piling system to be use in construction.

Give reasons for your choice.

[10 markah / marks]

- (d) Rajah 9.2 menunjukkan penghentak cerucuk berjisim 450 kg dilepaskan dari keadaan pegun.
Diagram 9.2 shows a pile driver of mass 450 kg release from stationary state.

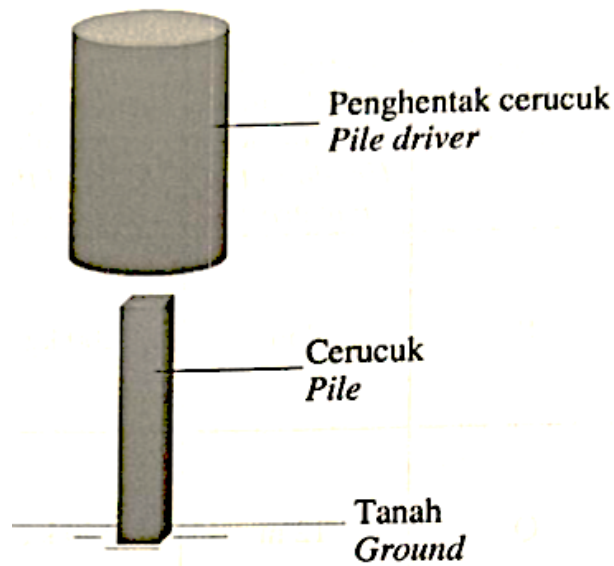

Rajah 9.2 / Diagram 9.2

Masa gerakan penghentak cerucuk sejeurus sebelum hentakan ialah 2 s.
The time of motion of the pile driver just before the impact is 2 s.

Hitung,
Calculate,

- (i) halaju penghentak cerucuk sejeurus sebelum hentaman
(nyatakan jawapan dengan unit)
the velocity of the pile driver just before the impact
(state the answer with the unit)
- (ii) Perubahan momentum penghentak cerucuk
(nyatakan jawapan dengan unit)
the change of momentum of the pile driver
(state the answer with the unit)

[3 markah / marks]

[2 markah / marks]

TOTAL 20 marks

F4 BAB 3: GRAVITI

SPM 2021 (SET 1)

- 3 Diagram 3 shows a rubber stopper of mass 0.2 kg is tied to one end with a nylon thread and hung to a load on the other end. The rubber stopper is spinned in a circular path at a constant speed.

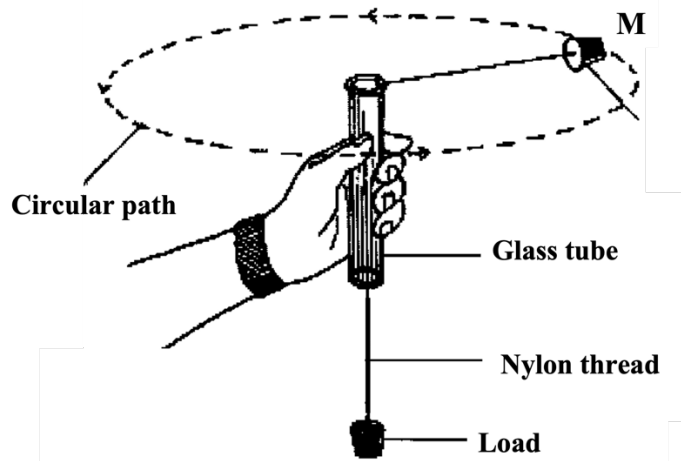

Diagram 3

- (a) Based on Diagram 3,
- (i) Name the force that remains the rubber stopper in the circular path.
.....
[1 mark]
 - (ii) mark the direction of force, F involved in 3(a)(i) in Diagram 3. [1 mark]
 - (iii) draw the arrow to show the direction of linear speed, v of rubber stopper at position M in Diagram 3. [1 mark]
- (b) The rubber stopper is spinned with linear speed of 10 m s^{-1} . Calculate the force acting on the rubber stopper when the radius of the circular path is 1.5 m.

$F = \dots\dots\dots \text{ N}$ [2 marks]

- (c) What will happen to the radius of the circular path when the rubber stopper is spinned with a higher speed?
.....
[1 mark]

TOTAL 6 marks

SPM 2021 (SET 2)

- 2 Rajah 2 menunjukkan satelit J dan satelit K mengelilingi Bumi. Hukum Kepler Ketiga menjelaskan hubungan antara tempoh orbit satelit mengelilingi Bumi dan jejari orbit tersebut. *Diagram 2 shows the satellite J and satellite K orbiting the Earth. Kepler's Third Law explains the relationship between the orbital period of a satellite around the Earth and its orbital radius.*

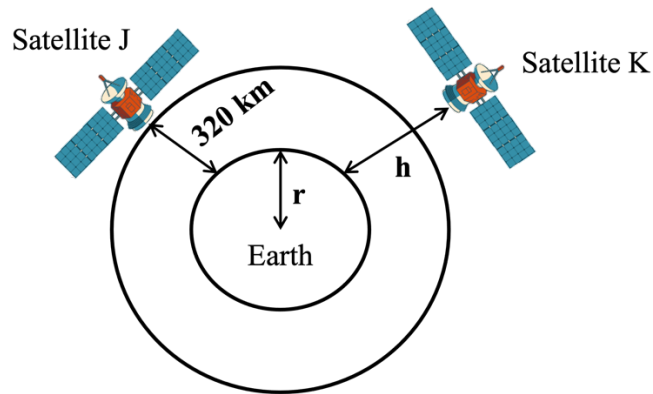

Diagram 2

- (a) Nyatakan Hukum Kepler Ketiga
State Kepler's Third law.

.....
[1 mark]

- (b) Satelit J dan satelit K masing-masing berada pada ketinggian 320 km dan h dari permukaan Bumi. Tempoh orbit satelit K mengelilingi Bumi adalah lima kali ganda tempoh orbit satelit J. Kira jejari orbit satelit K. [jejari Bumi, $r = 6370$ km]
Satellite J and satellite K are at a height of 320 km and h respectively from the Earth's surface. The orbital period of satellite K orbiting the Earth is five times the orbiting period of satellite J. Calculate the orbital radius of satellite K.
[Radius of the Earth, $r = 6370$ km]

[3 marks]

- (c) Apakah yang berlaku kepada laju linear satelit K, jika satelit itu sedang mengelilingi bumi dengan ketinggian, h yang lebih besar.
What happens to the linear speed of satellite K, if the satellite is orbiting the earth with greater height, h .

.....
[1 mark]

TOTAL 5 marks

SPM 2022

- 4 Rajah 4 menunjukkan satelit kaji cuaca sedang mengorbit bumi pada ketinggian 850 km. Satelit tersebut merupakan sebuah satelit bukan geopegun.

Diagram 4 shows a weather forecast satellite orbiting the earth at a high of 850 km.

The satellite is a non-geostationary satellite.

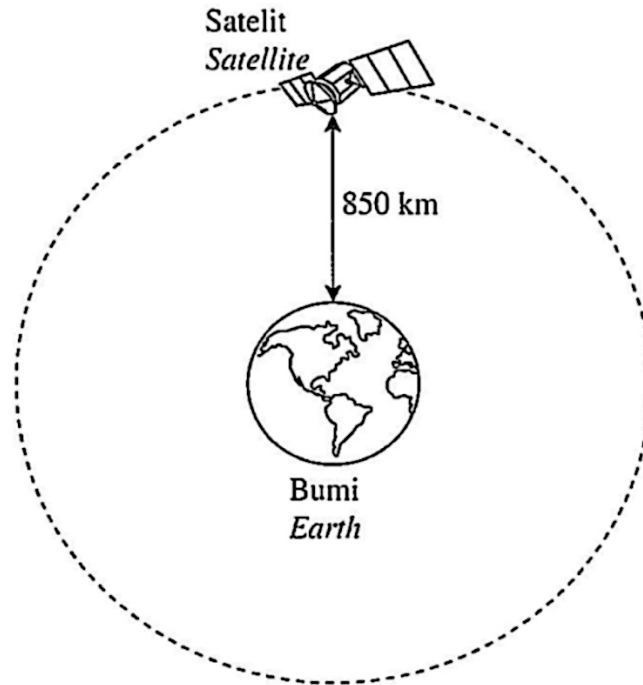

Rajah 4 / Diagram 4

- (a) Nyatakan satu ciri satelit bukan geopegun.
State one characteristic of non-geostationary satellite.

.....
[1 mark]

- (b) Diberi,
Given,
Jisim Bumi, M (*Mass of Earth*) = 5.97×10^{24} kg
Jejari Bumi, r (*Radius of Earth*) = 6.37×10^6 m
Pemalar kegravitian, G (*Gravitational constant*) = 6.67×10^{-11} N m² kg⁻²

Menggunakan rumus-rumus berikut:
Using these formulae:

$$v = \sqrt{\frac{GM}{r}} \quad \text{dan (and)} \quad T^2 = \frac{4\pi^2 r^3}{GM}$$

Hitung,
Calculate,

- (i) laju linear satelit itu
the linear speed of the satellite

[3 marks]

- (ii) tempoh satelit itu mengorbit bumi,
the period of the satellite orbiting the earth.

[2 marks]

- (c) Nyatakan tiga kesan kepada satelit apabila laju linear satelit berkurang daripada laju linear satelit yang sepatutnya.
State three effects on a satellite when the linear speed of a satellite decreases from the proper linear speed of a satellite.

.....
.....
.....

[3 marks]

TOTAL 9 marks

SPM 2023

- 7 Rajah 7 menunjukkan sebuah satelit komunikasi mengelilingi Bumi dan kekal pada ketinggian, $h = 30\,500$ km dari permukaan Bumi. Jejari Bumi, $R = 6\,370$ km.
Diagram 7 shows a communication satellite orbiting the Earth and remains at a height, $h = 30\,500$ km from the Earth's surface. The radius of the Earth, $R = 6\,370$ km.

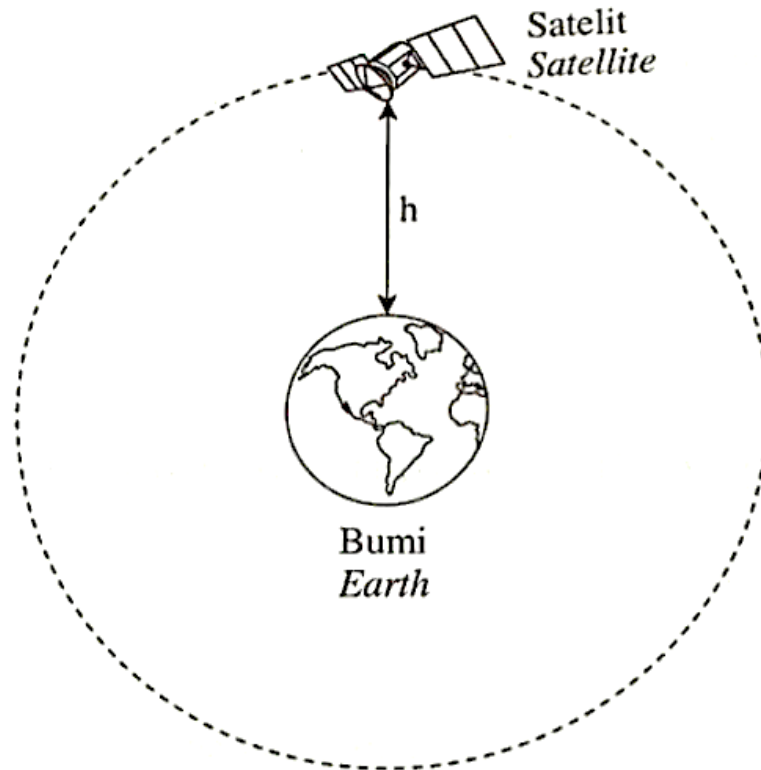

Rajah 7 / Diagram 7

- (a) Namakan daya yang mengekalkan satelit pada orbitnya.
Name the force that keeps a satellite on its orbit.

.....
[1 markah / mark]

- (b) Berdasarkan Rajah 7, hitung,
Based on Diagram 7, calculate,

- (i) jejari orbit, r
radius of orbit, r

$r = \dots\dots\dots$ km

[1 markah / mark]

- (ii) laju linear satelit, v
linear speed of satellite, v

[2 markah / marks]

- (c) Jadual 7 menunjukkan ciri-ciri bagi tiga buah satelit yang berbeza.
Table 7 shows the characteristic of three different satellites.

Satelit <i>Satellite</i>	Jenis satelit <i>Type of satellite</i>	Tempoh orbit <i>Orbital period</i>
P	Geopegun <i>Geostationary</i>	24 jam <i>24 hours</i>
Q	Bukan geopegun <i>Non-geostationary</i>	24 jam <i>24 hours</i>
R	Geopegun <i>Geostationary</i>	12 jam <i>12 hours</i>

Jadual 7 / Table 7

Berdasarkan Jadual 7, nyatakan ciri-ciri yang sesuai bagi sebuah satelit komunikasi yang boleh digunakan oleh agensi telekomunikasi untuk siaran langsung ke seluruh dunia.

Based on Table 7, state the suitable characteristics of the communication satellite that can be used by a telecommunications agency for live broadcast around the world.

- (i) Jenis satelit
Type of satellite

.....
 [1 markah / mark]

Sebab
Reason

.....
 [1 markah / mark]

(ii) Tempoh orbit
Orbital period

.....
[1 markah / mark]

Sebab
Reason

.....
[1 markah / mark]

(d) Berdasarkan jawapan anda di 7(c)(i) dan 7(c)(ii), tentukan satelit yang paling sesuai dipilih oleh agensi telekomunikasi tersebut.
Based on the answer in 7(c)(i) and 7(c)(ii), determine the most satellite that should be chosen by the telecommunications agency.

.....
[1 markah / mark]

TOTAL 9 marks

SPM 2024

- 8 Rajah 7 menunjukkan satelit kaji cuaca yang mengorbit Bumi dengan laju linear, v .
Diagram 7 shows a weather satellite orbiting the Earth with a linear speed, v .

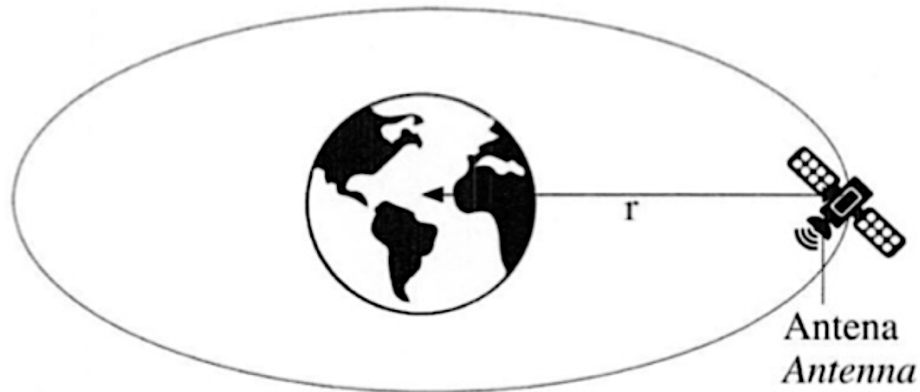

Rajah 7 / Diagram 7

- (a) Nyatakan jenis satelit bagi satelit kaji cuaca.
State the type of satellite for the weather satellite.

.....
[1 markah / mark]

- (b) Berdasarkan Rajah 7, hitung laju linear satelit kaji cuaca tersebut.
Based on Diagram 7, calculate the linear speed of the weather satellite.

[Jejari orbit satelit / *Orbital radius of satellite*, $r = 4.237 \times 10^7$ m]

[2 markah / marks]

- (c) Cadangkan ciri satelit kaji cuaca yang dapat mengumpul maklumat berkaitan cuaca dengan tepat berdasarkan aspek berikut:

Suggest the characteristics of the weather satellites that can accurately collect weather-related information based on the following aspects:

- (i) Saiz antena
The size of the antenna

.....

Sebab
Reason

.....

[2 markah / marks]

- (ii) Sumber tenaga satelit
The energy source of the satellite

.....

Sebab
Reason

.....

[2 markah / marks]

- (iii) Jisim satelit
The mass of the satellite

.....

Sebab
Reason

.....

[2 markah / marks]

TOTAL 9 marks

F4 BAB 4: HABA

SPM 2021 (SET 1)

1 Diagram 1 shows a cooling curve for a metal in a liquid state.

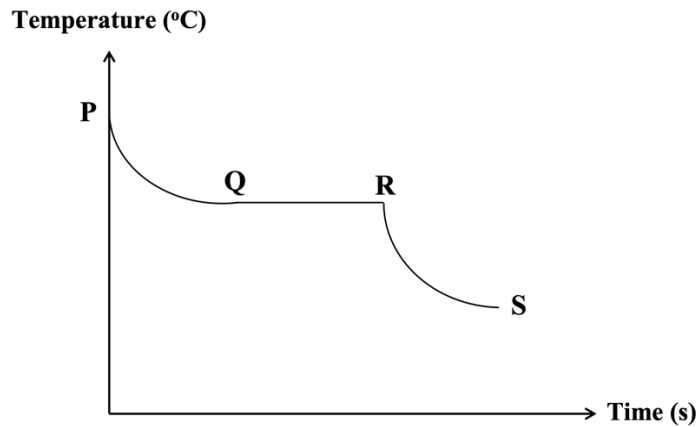

Diagram 1

(a) Temperature of the metal is constant from Q to R.

(i) State the type of heat involved from Q to R. Tick (✓) in the box for the correct answer.

Heat capacity

Latent heat

[1 mark]

(ii) Name the state of matter from Q to R.

.....

[1 mark]

(iii) Give one reason why the temperature is constant from Q to R.

.....

[1 mark]

(c) What happened to the heat energy during the cooling process from R to S?

.....

[1 mark]

TOTAL 4 marks

SPM 2021 (SET 2)

- 10** Rajah 10.1 menunjukkan satu pad penyejuk yang digunakan oleh seorang kanak-kanak untuk mengurangkan demam. Pad penyejuk berfungsi berdasarkan prinsip keseimbangan terma.
Diagram 10.1 shows a cooling pad that is used by a child to reduce the fever. The cooling pad works based on the principle of thermal equilibrium.



Diagram 10.1

- (a) Apakah maksud keseimbangan terma?
What is meant by thermal equilibrium? [1 mark]
- (b) Terangkan bagaimana penggunaan pad penyejuk boleh menurunkan suhu badan.
Explain how the usage of a cooling pad can lower the body temperature. [4 marks]
- (c) Rajah 10.2 menunjukkan satu bantal pemanas yang digunakan untuk melegakan kesakitan otot.
Diagram 10.2 shows a heating pillow that is used to relieve the muscle pain.



Diagram 10.2

Jadual 10 menunjukkan empat jenis bantal pemanas A, B, C dan D.
Table 10 shows four types of heating pillows A, B, C and D.

Bantal pemanas <i>Heating pillow</i>	Bahan di dalam bantal pemanas <i>Substance inside the heating pillow</i>	Muatan haba tentu bahan <i>Specific heat capacity of material</i>	Bahan untuk sarung bantal <i>Material of pillow case</i>	Takat didih bahan <i>Boiling point of material</i>
A	Gel <i>Gel</i>	Rendah <i>Low</i>	Kanvas <i>Canvas</i>	Rendah <i>Low</i>
B	Cecair <i>Liquid</i>	Tinggi <i>High</i>	Kanvas <i>Canvas</i>	Tinggi <i>High</i>
C	Gel <i>Gel</i>	Tinggi <i>High</i>	Nilon <i>Nylon</i>	Tinggi <i>High</i>
D	Cecair <i>Liquid</i>	Rendah <i>Low</i>	Nilon <i>Nylon</i>	Rendah <i>Low</i>

Table 10

Terangkan kesesuaian setiap ciri bantal pemanas dan tentukan pemanas yang paling sesuai. Berikan sebab bagi pilihan anda.

Explain the suitability of each characteristics and determine the most suitable heating pillow. Give reason for your choice.

[10 marks]

- (d) Sebuah cerek elektrik berlabel 240 V, 1 kW diisi dengan 0.8 kg air pada suhu 30 °C.

[Muatan haba tentu air, $c = 4200 \text{ J kg}^{-1} \text{ }^\circ\text{C}^{-1}$]

An electric kettle labelled 240 V, 1 kW is filled with 0.8 kg of water at temperature of 30 °C. [Specific heat capacity of water, $c = 4200 \text{ J kg}^{-1} \text{ }^\circ\text{C}^{-1}$]

- (i) Hitung tenaga haba yang diperlukan untuk menaikkan suhu air kepada 100 °C.
Calculate the heat energy needed to raise the temperature of water to 100 °C.

[3 marks]

- (ii) Hitung masa yang diperlukan untuk air itu mendidih.
Calculate the time required for the water to boil.

[2 marks]

TOTAL 20 marks

- 11 Rajah 11.1(a) dan Rajah 11.1(b) menunjukkan suhu awal cecair X sebelum dipanaskan oleh pemanas rendam yang sama.

Diagram 11.1(a) and Diagram 11.1(b) show the initial temperatures of liquid X before being heated by identical immersion heater.

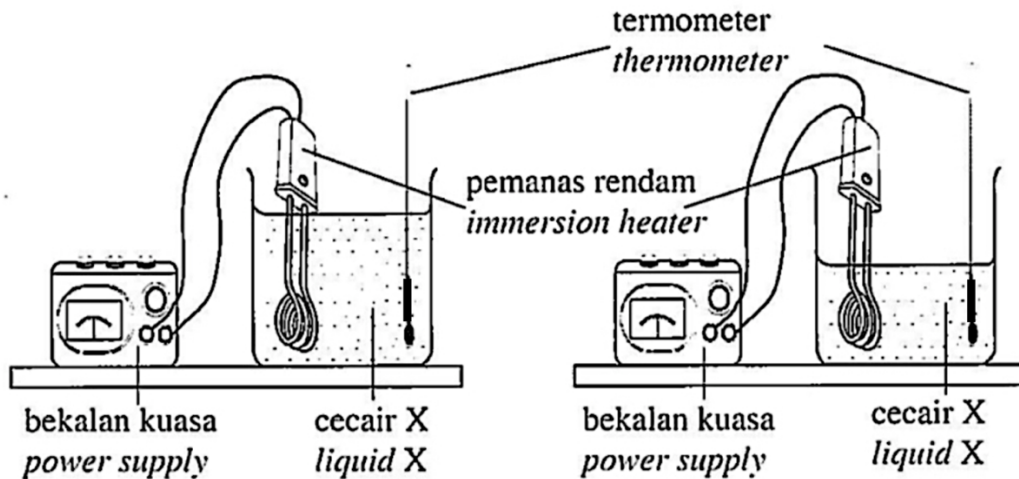

Rajah 11.1(a) / Diagram 11.1(a)

Rajah 11.1(b) / Diagram 11.1(b)

Rajah 11.2(a) dan Rajah 11.2(b) menunjukkan suhu akhir cecair X selepas dipanaskan selama 10 minit.

Diagram 11.2(a) and Diagram 11.2(b) show the final temperatures of liquid X after being heated for 10 minutes.

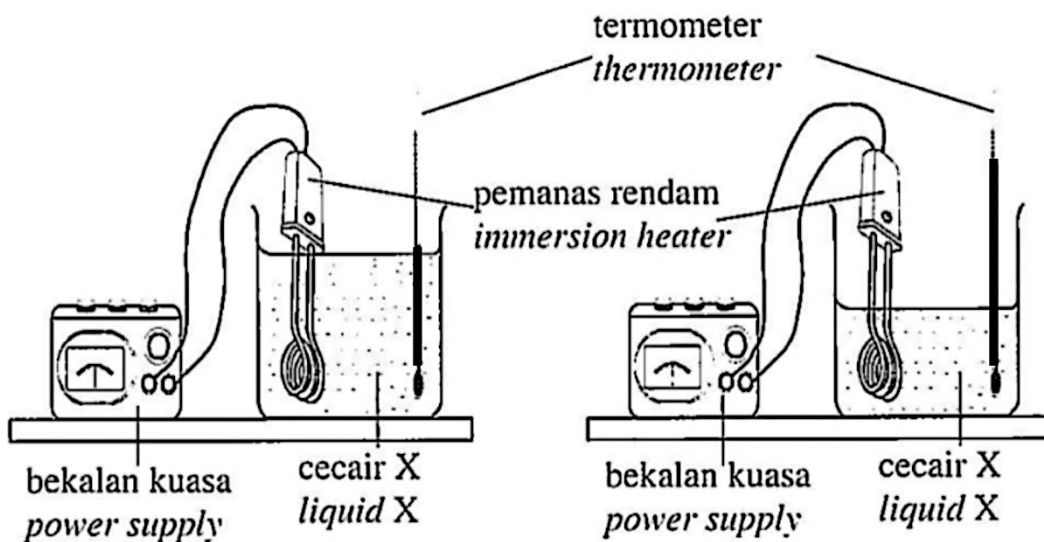

Rajah 11.2(a) / Diagram 11.2(a)

Rajah 11.2(b) / Diagram 11.2(b)

- (a) Apakah maksud suhu?
What is the meaning of temperature?

[1 mark]

- (b) (i) Berdasarkan Rajah 11.1(a) dan Rajah 11.1(b), bandingkan suhu awal dan jisim cecair X sebelum dipanaskan.
Based on Diagram 11.1(a) dan Diagram 11.1(b), compare the initial temperature and masses of liquid X before being heated.
- (ii) Berdasarkan Rajah 11.2(a) dan Rajah 11.2(b), bandingkan kenaikan suhu cecair X selepas dipanaskan.
Based on Diagram 11.2(a) dan Diagram 11.2(b), compare the rise in temperature of liquid X after heating.
- (iii) Hubungkan jisim dengan kenaikan suhu. Nyatakan kuantiti fizik yang mesti dimalarkan bagi mendeduksikan hubungan antara jisim dengan kenaikan suhu.
Relate the mass and rise in the temperature. State the physical quantity that must be kept constant to deduce the relationship between the mass and the rise in temperature.

[5 marks]

- (c) Baca pernyataan di bawah.
Read the statement below.

Haba daripada Matahari memanaskan pasir di pantai dan air laut dalam tempoh yang sama. Didapati pasir lebih cepat panas daripada air laut.

The heat from the Sun heats up the sand on the beach and sea water in same period. It is found that the sand heats up faster than the sea water.

Menggunakan konsep fizik yang betul, jelaskan pernyataan di atas.
Using the correct physics concept, explain the above statement.

[4 marks]

- (d) Rajah 11.3 menunjukkan sebuah rumah berkonsepkan bangunan hijau. Bangunan hijau adalah bangunan yang memberikan impak positif terhadap iklim dan persekitaran semula jadi.

Diagram 11.3 shows a house with a green building concept. A green building is a building that gives a positive impact on climate and the natural environment.



Rajah 11.3 / Diagram 11.3

Menggunakan konsep fizik yang sesuai, cadangkan penggunaan bahan dan reka bentuk yang sesuai untuk meningkatkan pengudaraan dan memastikan suhu dalam rumah itu tidak tinggi. Cadangan anda mestilah merangkumi muatan haba tentu bahan dan jenis bahan yang digunakan sebagai dinding dan bumbung rumah, bilangan tingkap dan reka bentuk rumah.

Using appropriate physics concepts, suggest the use of appropriate materials and appropriate design to increase ventilation and ensure that the temperature in the house is not high. Your proposal must include the specific heat of the material and the type of material used as the walls and roof of the house, the number of windows and the design of the house.

[10 marks]

TOTAL

20 Marks

SPM 2023

- 1 Rajah 1 menunjukkan fenomena yang berlaku disebabkan perbezaan muatan haba tentu antara daratan dengan lautan.

Diagram 1 shows a phenomenon that occurs due to the difference of specific heat capacity between land and ocean.

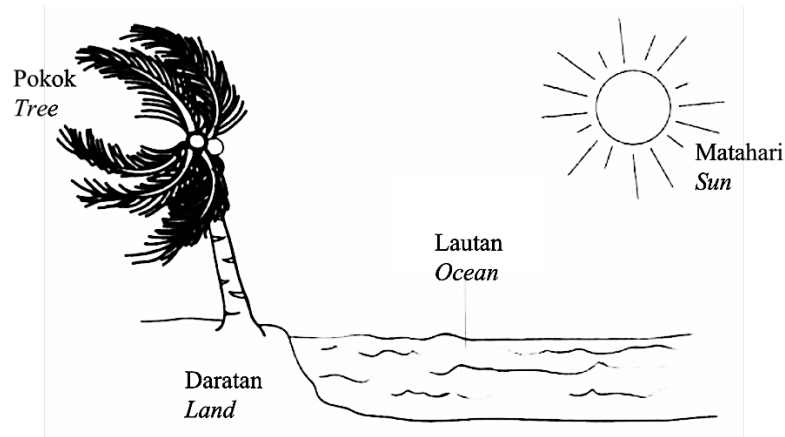

Rajah 1 / Diagram 1

- (a) Apakah maksud muatan haba tentu?
What is meant by specific heat capacity?

.....

[1 markah / mark]

- (b) (i) Tandakan (✓) pada petak untuk jawapan yang betul.
Tick (✓) in the box for the correct answer.

Pada waktu siang, daratan lebih cepat panas
During day time, land heats up faster

Pada waktu siang, air laut lebih cepat panas
During day time, sea water heats up faster

[1 markah / mark]

- (ii) Beri satu sebab bagi jawapan di 1(b)(i).
Give one reason for the answer in 1(b)(i).

.....

[1 markah / mark]

- (c) Namakan fenomena yang berlaku dalam Rajah 1.
Name the phenomenon that occurs in Diagram 1.

.....

[1 markah / mark]

TOTAL 4 marks

SPM 2024

- 6 Dua biji bola ping pong kemek yang serupa direndam ke dalam air yang bersuhu 45°C dan 90°C. Rajah 5.1 dan Rajah 5.2 menunjukkan bentuk bola ping pong tersebut setelah direndam untuk beberapa minit.

Two identical dented ping pong balls are immersed into water at 45°C and 90°C. Diagrams 5.1 and 5.2 show the shapes of the ping pong balls after being soaked for a few minutes.

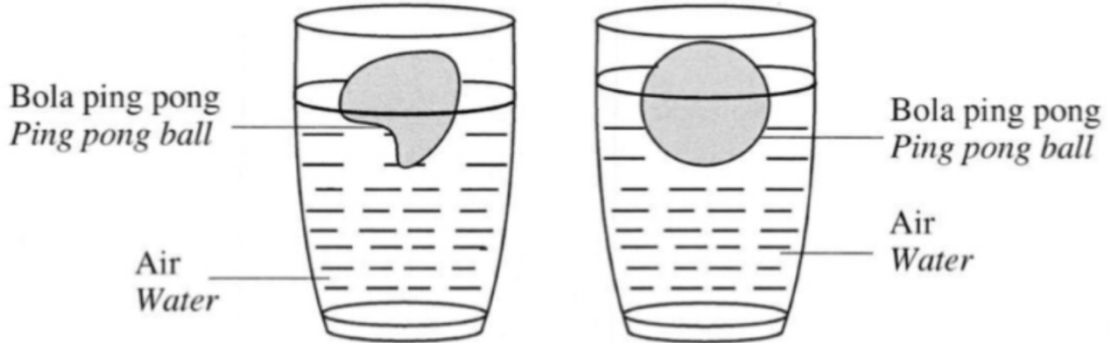

Rajah 5.1 / Diagram 5.1 Rajah 5.2 / Diagram 5.2

- (a) Nyatakan satu kuantiti fizik yang menyebabkan bentuk bola ping pong berubah setelah direndam.

State one physical quantity that causes the shape of the ping pong ball to change after being soaked.

.....
[1 markah / mark]

- (b) Mengapakah isipadu bola ping pong yang kemek bertambah apabila direndam dalam air panas?

Why does the volume of a dented ping pong ball increase when soaked in hot water?

.....
[1 markah / mark]

- (c) Berdasarkan Rajah 5.1 dan Rajah 5.2,
Based on Diagrams 5.1 and 5.2,

- (i) bandingkan suhu air
compare the temperature of water

.....
[1 markah / mark]

- (ii) bandingkan isipadu bola ping pong selepas direndam untuk beberapa minit
compare the volumes of ping pong balls after soaked for a few minutes

.....

[1 markah / mark]

- (iii) nyatakan kuantiti fizik yang dimalarkan supaya isipadu kedua-dua bola ping pong bertambah.
state the physical quantity that is kept constant so that the volumes of both ping pong balls increase.

.....
[1 markah / mark]

- (d) (i) Berdasarkan jawapan di 6(c), nyatakan hubungan antara suhu dengan isipadu.
Based on the answer in 6(c), state the relationship between the temperature and the volume.

.....
[1 markah / mark]

- (ii) Nyatakan hukum fizik yang terlibat dalam 6(d)(i).
State the law of physics involved in 6(d)(i).

.....
[1 markah / mark]

- (e) Suhu awal air dalam Rajah 5.2 ialah 28°C.
Hitung isipadu bola ping pong kemek sebelum direndam ke dalam air jika isipadu sebenar bola ping pong adalah 33.5 cm³.
*The initial temperature of water in Diagram 5.2 is 28°C.
Calculate the volume of the dented ping pong ball before it is immersed in water if the actual volume of the ping pong ball is 33.5 cm³.*

[2 markah / marks]

TOTAL 9 marks

F4 BAB 5: GELOMBANG

SPM 2021 (SET 1)

- 5 Diagram 5.1 shows water waves are produced when the man continuously dipping his feet in the water with a constant rate.

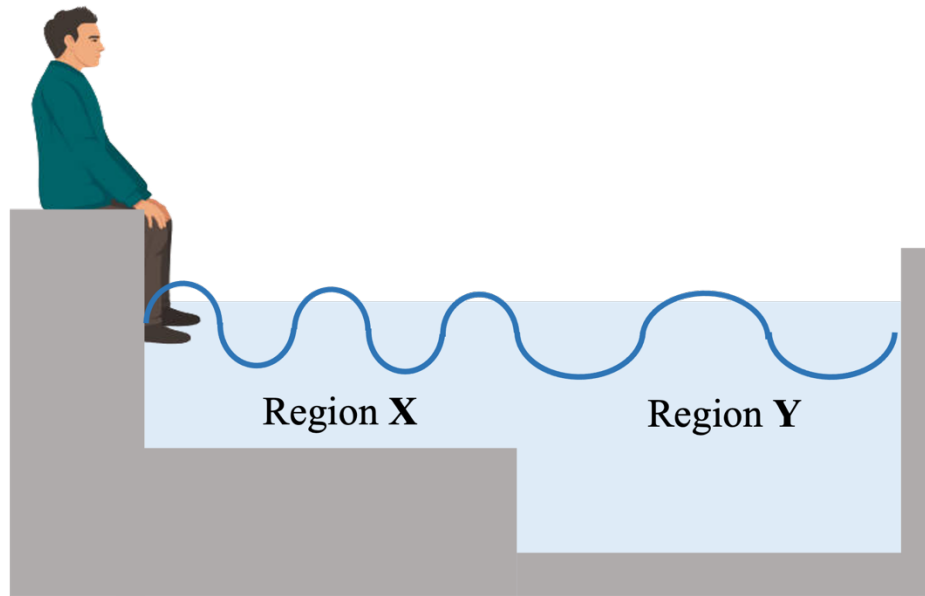

Diagram 5.1

- (a) Tick (✓) for the correct answer in the box provided.
Water wave is

transverse waves

longitudinal waves

[1 mark]

- (b) Observe Diagram 5.1. Compare region X and region Y in terms of

- (i) depth of water

.....

[1 mark]

- (ii) wavelength

.....

[1 mark]

(iii) frequency

.....
[1 mark]

(c) Relate the wavelength and depth of water.

.....
[1 mark]

(d) Name the wave phenomenon involved.

.....
[1 mark]

(e) Diagram 5.2 shows the propagation of waves from deep water region to shallow water region towards headland that happens in a sea area.

(i) In Diagram 5.2, draw the direction of propagation for the water wave when the waves approach the headland.

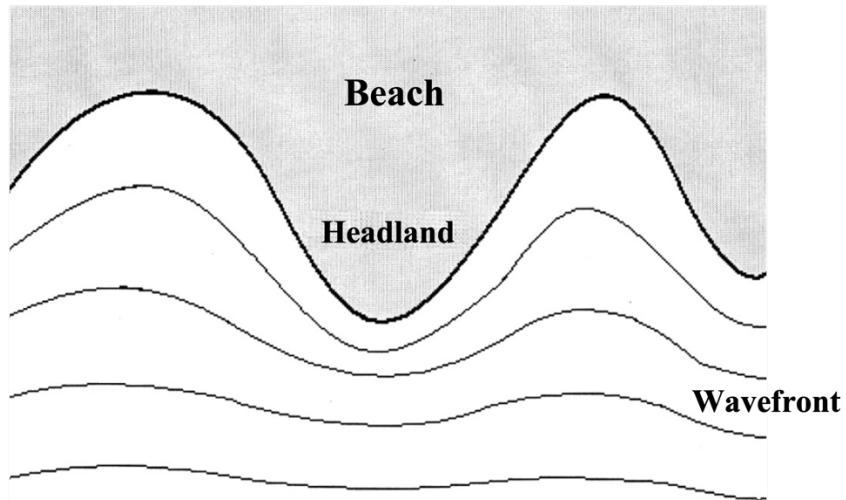

Diagram 5.2

[1 mark]

(ii) In shallow water region, the wavelength and the speed of wave is 8 m and 2.5 m s^{-1} respectively.
Calculate the speed of the water wave in deep water region when the wavelength of the wave in the region is 20 m.

[2 marks]

TOTAL 9 marks

SPM 2021 (SET 2)

- 4 Rajah 4.1 menunjukkan seorang budak lelaki melompat dari sebatang dahan pokok ke dalam sebuah tasik. Dahan itu bergetar seketika sebelum berhenti.
Diagram 4.1 shows a boy jumping from a tree branch into a lake. The branch vibrates before it stopped.

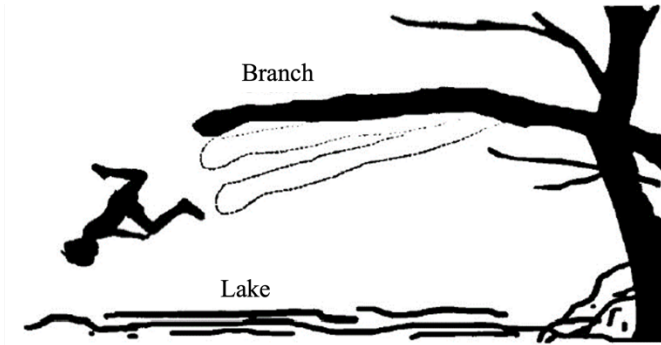

Diagram 4.1

- (a) Nyatakan fenomenon yang berlaku kepada dahan itu.
State the phenomenon that occurs to the branch.

.....
[1 mark]

- (b) (i) Apakah yang berlaku kepada amplitud getaran dahan itu? Jelaskan jawapan anda.
What happen to the amplitude of vibration of the branch? Explain your answer.

.....
.....
[2 marks]

- (ii) Lakarkan graf amplitud melawan masa bagi getaran dahan tersebut dalam Rajah 4.2.
Sketch a graph of amplitude against time for the vibration of the branch in Diagram 4.2.

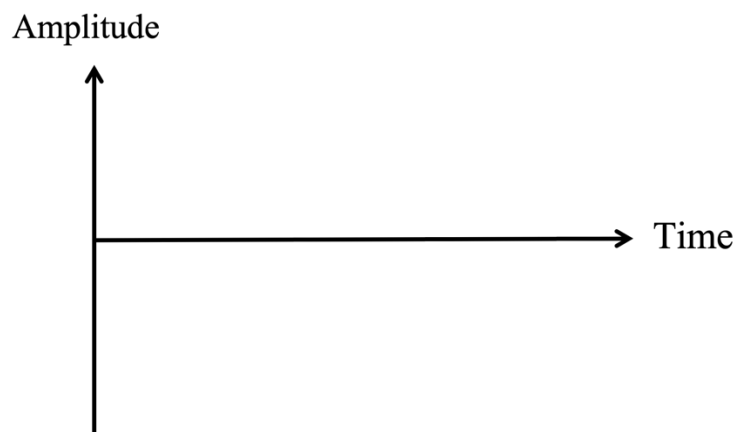

Diagram 4.2

[1 mark]

- (c) Apabila budak lelaki itu terjun ke dalam tasik, gelombang air terhasil. Rajah 4.3 menunjukkan graf sesaran melawan masa bagi gelombang air tersebut.
When the boy jumps into the lake, a water waves is produced. Diagram 4.3 shows a graph of displacement against time for the water waves.

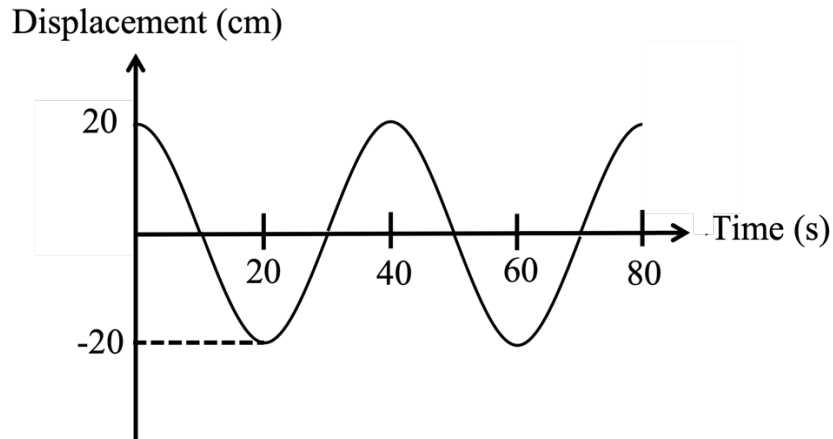

Diagram 4.3

- (i) Berdasarkan Rajah 4.3, tentukan amplitud dan panjang gelombang bagi gelombang air itu.
Based on Diagram 4.3, determine the amplitude and the wavelength of the water waves.

Amplitud : cm
Amplitude

Panjang gelombang: cm
Wavelength

[2 marks]

- (ii) Frekuensi gelombang air itu ialah 5 Hz. Berdasarkan jawapan anda di 4(c)(i), hitung laju gelombang air itu.
The frequency of the water waves is 5 Hz. Based on your answer in 4(c)(i), calculate the speed of the water waves.

[2 marks]

- (iii) Jika kedalaman air bertambah, apakah yang berlaku kepada panjang gelombang bagi gelombang air tersebut?
If the depth of water increases, what happens to the wavelength of the water waves?

.....
 [1 mark]

TOTAL 9 marks

SPM 2022

- 5 Rajah 5.1 dan Rajah 5.2 menunjukkan kesan superposisi dua sumber gelombang air S_1 dan S_2 yang koheren.

Diagram 5.1 and 5.2 show the effect of the superposition of two coherent water wave sources S_1 and S_2 .

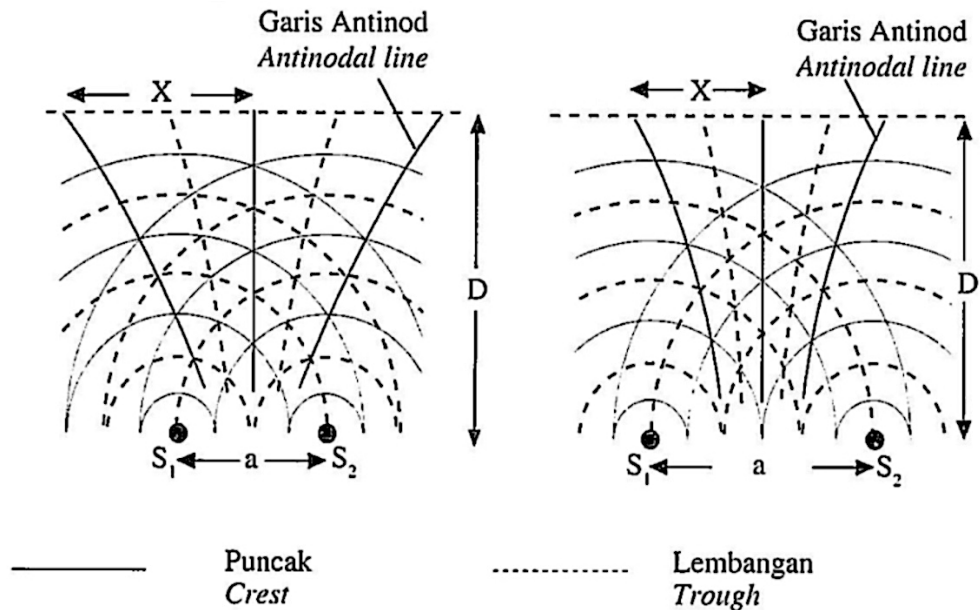

Rajah 5.1 / Diagram 5.1

Rajah 5.2 / Diagram 5.2

- (a) Apakah maksud dua sumber koheren?
What is the meaning of two coherent sources?

..... [1 mark]

- (b) Perhatikan Rajah 5.1 dan Rajah 5.2. Bandingkan,
Observe Diagram 5.1 dan 5.2. Compare,

- (i) Jarak antara dua sumber koheren, a .
The distance between two coherent sources, a .

..... [1 mark]

- (ii) Jarak antara dua garis antinod berturutan, X .
The distance between two consecutive antinodal lines, X .

..... [1 mark]

- (iii) Jarak antara dua sumber koheren ke garis pengesan, D .
The distance between two coherent sources to the detector line, D .

..... [1 mark]

(c) Berdasarkan jawapan anda dalam 5(b).

Based on your answer in 5(b).

(i) Hubungkan antara dua sumber koheren, a dengan jarak antara dua garis antinod berturutan, X.

Relate the distance between two coherent sources, a and the distance between two consecutive antinodal line, X.

.....
[1 mark]

(ii) Namakan fenomena gelombang yang terlibat.

Name the wave phenomenon involved.

.....
[1 mark]

(d)

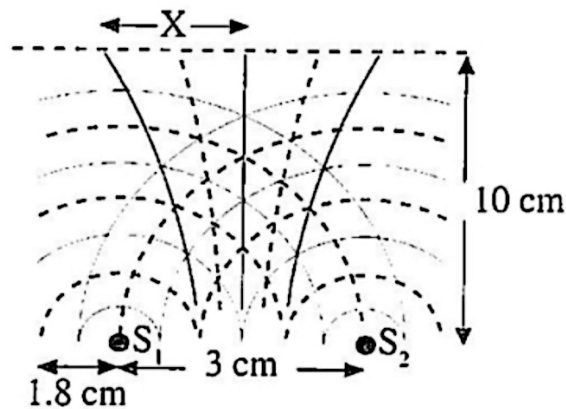

Rajah 5.3 / Diagram 5.3

(i) Berdasarkan Rajah 5.3, hitung jarak antara dua garis antinod berturutan, X.

Based on Diagram 5.3, calculate the distance between two consecutive antinodal lines, X.

[2 marks]

(ii) Apakah yang akan berlaku kepada jarak di antara dua garis antinod berturutan, X jika frekuensi gelombang ditingkatkan.

What will happen to the distance between two consecutive antinodal lines, X if the frequency of waves is increased.

.....
[1 mark]

TOTAL 9 marks

SPM 2023

- 5 Rajah 5.1 dan Rajah 5.2 menunjukkan corak gelombang air selepas melalui celah yang berlainan saiz. Panjang gelombang, λ dan frekuensi gelombang tuju, f adalah serupa. *Diagram 5.1 and Diagram 5.2 show the pattern of water wave after passing through slits with different sizes. The wavelength, λ and frequency of the incident wave, f are similar.*

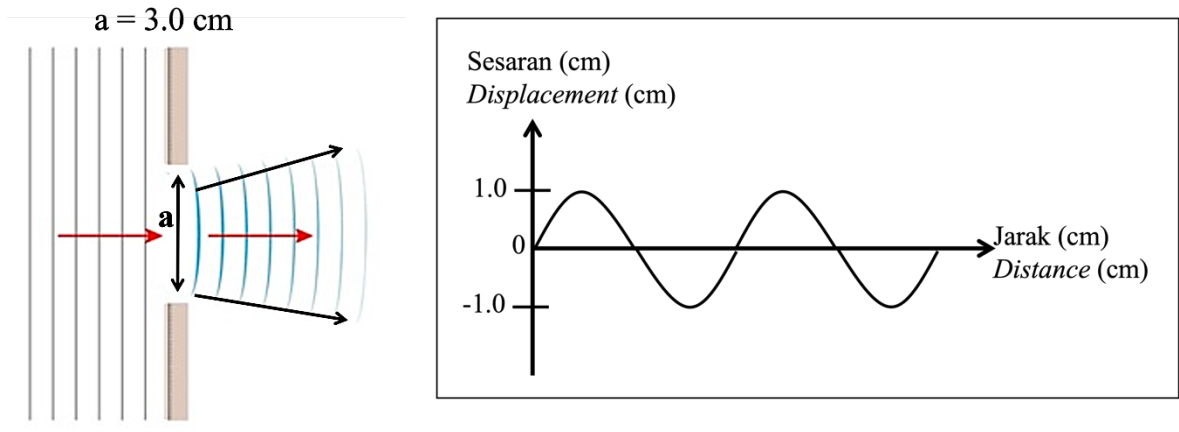

Rajah 5.1 / Diagram 5.1

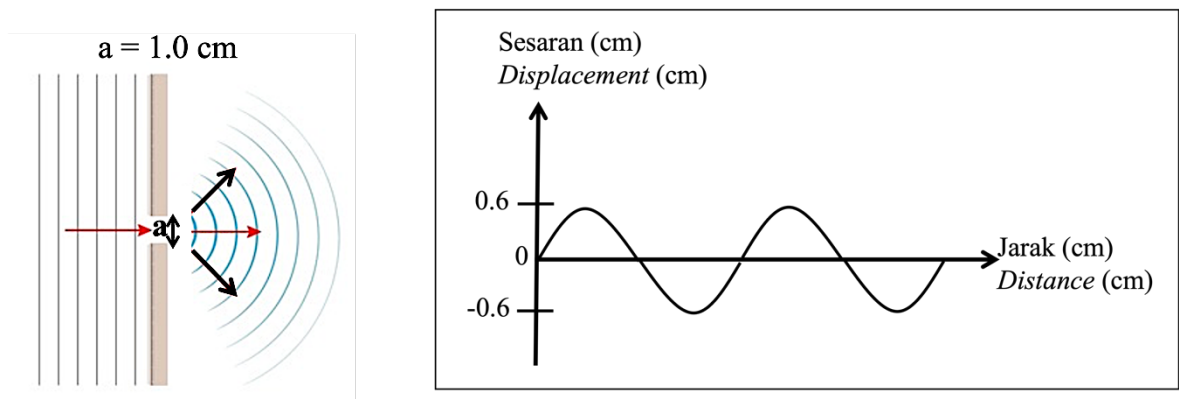

Rajah 5.2 / Diagram 5.2

- (a) Namakan fenomena yang berlaku dalam Rajah 5.2.
Name the wave phenomenon that occurs in Diagram 5.2.

.....
[1 markah / mark]

- (b) Perhatikan Rajah 5.1 dan Rajah 5.2. Bandingkan,
Observe Diagram 5.1 and Diagram 5.2. Compare,

- (i) saiz celah
size of the slit

.....
[1 markah / mark]

(ii) amplitud gelombang selepas melalui celah
the amplitude of waves after passing through the slit

.....
[1 markah / mark]

(iii) penyebaran gelombang selepas melalui celah
spreading of waves after passing through the slit

.....
[1 markah / mark]

(c) Berdasarkan jawapan anda di 5(b),
Based on your answer in 5(b),

(i) hubungkaitkan saiz celah dengan penyebaran gelombang
relate the size of the slit with the spreading of waves

.....
[1 markah / mark]

(ii) hubungkaitkan amplitud gelombang dengan penyebaran gelombang
relate the amplitude of waves with the spreading of waves

.....
[1 markah / mark]

(d) Mengapakah amplitud gelombang berubah selepas gelombang air melalui celah?
Why the amplitude of waves changes after the water waves pass through the slit?

.....
[1 markah / mark]

- (e) Rajah 5.3 menunjukkan satu sistem siren banjir yang digunakan untuk memberi amaran kepada penduduk di sebuah Kawasan perumahan.
Diagram 5.3 shows a flood siren system used to give warning to the residents in a housing area.

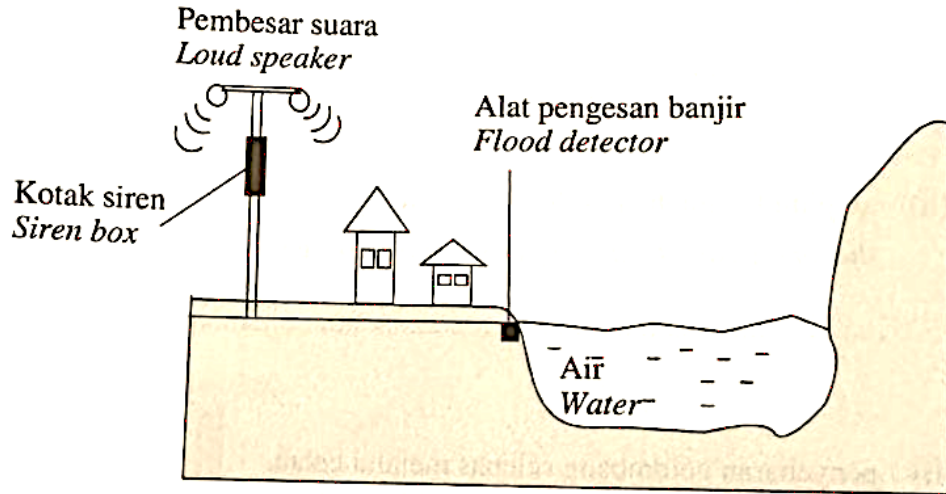

Rajah 5.3 / Diagram 5.3

Bunyi yang dihasilkan oleh pembesar suara tidak dapat didengari dengan jelas oleh penduduk di Kawasan perumahan tersebut.

Apakah perubahan yang perlu dilakukan terhadap frekuensi gelombang untuk mengatasi masalah tersebut?

Terangkan jawapan anda.

Sound produced by the speakers was not able to be heard clearly by the residents in the housing area.

What is the change that needs to be done on the frequency of wave to overcome the problem?

Explain your answer.

.....

.....

[2 markah / marks]

TOTAL 9 marks

SPM 2024

- 9 Rajah 8.1 menunjukkan dua sumber koheren, S_1 dan S_2 yang menghasilkan interferens gelombang.

Diagram 8.1 shows two coherent sources, S_1 and S_2 that produce wave interference.

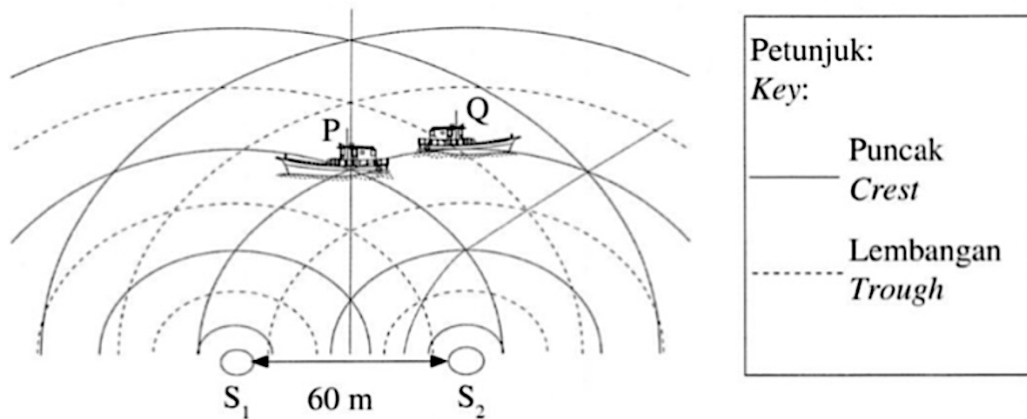

Rajah 8.1 / Diagram 8.1

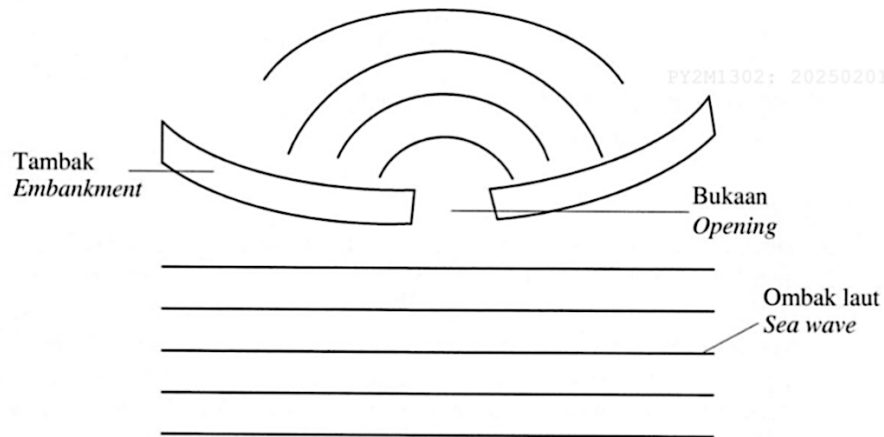

- (a) Nyatakan satu contoh gelombang melintang.
State one example of a transverse wave.
- [1 markah / mark]
- (b) Dua buah bot yang serupa, P dan Q seperti dalam Rajah 8.1 berada pada kedudukan yang berbeza di permukaan air. Bot P kelihatan berayun lebih kuat manakala bot Q berada dalam keadaan tenang.
Terangkan mengapa situasi itu berlaku.
Two similar boats, P and Q as in Diagram 8.1 are at different positions on the water surface. Boat P appears to swing more strongly while boat Q is in a calm situation. Explain why the situation occurred.
- [4 markah / marks]
- (c) Jika panjang gelombang bagi gelombang air laut yang merambat ialah 34 m, jarak pengukuran dari sumber koheren ke bot tersebut ialah 50 m dan halaju gelombang ialah 20 ms^{-1} .
Hitung,
If the wavelength of propagating sea wave is 34 m, the measurement distance from the coherent source to the boat is 50 m and the wave velocity is 20 ms^{-1} . Calculate,
- (i) jarak terdekat yang mungkin antara bot P dan bot Q
the closest possible distance between boat P and boat Q
- [3 markah / marks]
- (ii) frekuensi gelombang air laut tersebut.
the frequency of the sea waves.
- [2 markah / marks]

- (d) Rajah 8.2 menunjukkan tambak pemecah ombak.
 Diagram 8.2 shows the wave breaker embankment.



Rajah 8.2 / Diagram 8.2

Jadual 3 menunjukkan ciri-ciri bagi empat tambak pemecah ombak, K, L, M dan N.
 Table 3 shows the characteristics of four wave breaker embankments, K, L, M and N.

Jenis tambak pemecah ombak <i>Type of wave breaker embankment</i>	Ketinggian tambak <i>The height of the embankment</i>	Bukaan tambak <i>The opening of the embankment</i>	Bentuk tambak <i>The shape of the embankment</i>	Permukaan tambak <i>The surface of the embankment</i>
K	Tinggi <i>High</i>	Sempit <i>Narrow</i>	 Tegak <i>Straight</i>	Licin <i>Smooth</i>
L	Rendah <i>Low</i>	Luas <i>Wide</i>	 Becerun <i>Sloped</i>	Licin <i>Smooth</i>
M	Tinggi <i>High</i>	Sempit <i>Narrow</i>	 Becerun <i>Sloped</i>	Kasar <i>Rough</i>
N	Rendah <i>Low</i>	Luas <i>Wide</i>	 Tegak <i>Straight</i>	Kasar <i>Rough</i>

Jadual 3 / Table 3

Anda dikehendaki menyiasat ciri tambak pemecah ombak yang sesuai dibina untuk mengurangkan kesan hakisan pada pantai.

Terangkan kesesuaian setiap ciri dan tentukan tambak pemecah ombak yang paling sesuai. Berikan sebab-sebab bagi pilihan anda.

You are required to investigate the characteristics of suitable wave breaker embankment to be built to reduce the effects of erosion on the beach.

Explain the suitability of each characteristic and determine the most suitable wave breaker embankment. Give reasons for your choice.

[10 markah / marks]

TOTAL 20 marks

F4 BAB 6: CAHAYA & OPTIK

SPM 2021 (SET 1)

8 Diagram 8 shows a ring that consist of gemstone.



Diagram 8

- (a) The gemstone sparkles.
State the physics phenomenon involved.

.....
[1 mark]

- (b) The refractive index of the ring's gemstone is 1.5.
Calculate the critical angle of the gemstone.

[2 marks]

- (c) If the gemstone in Diagram 8 is less sparkle, state the characteristic of the following aspects to replace the gemstone in Diagram 8 to be more sparkled.

- (i) Critical angle

.....
[1 mark]

Reason

.....
[1 mark]

(ii) Optical density

..... [1 mark]

Reason

..... [1 mark]

(iii) Surface of gemstone

..... [1 mark]

Reason

..... [1 mark]

TOTAL 9 marks

SPM 2021 (SET 2)

- 11 Rajah 11.1 dan Rajah 11.2 menunjukkan sinar cahaya selari dari kedudukan yang sama. Panjang fokus kana ditentukan apabila sinar cahaya tersebut ditumpukan selepas melalui kanta.

Diagram 11.1 and Diagram 11.2 show parallel rays from the same position.

Focal length of the lens is determined when the rays converged after passing through the lens.

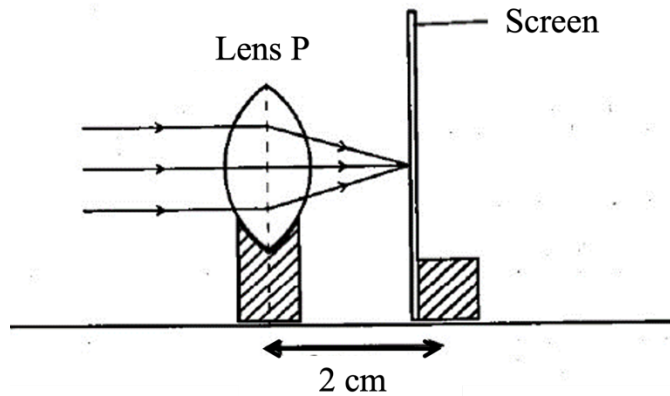

Diagram 11.1

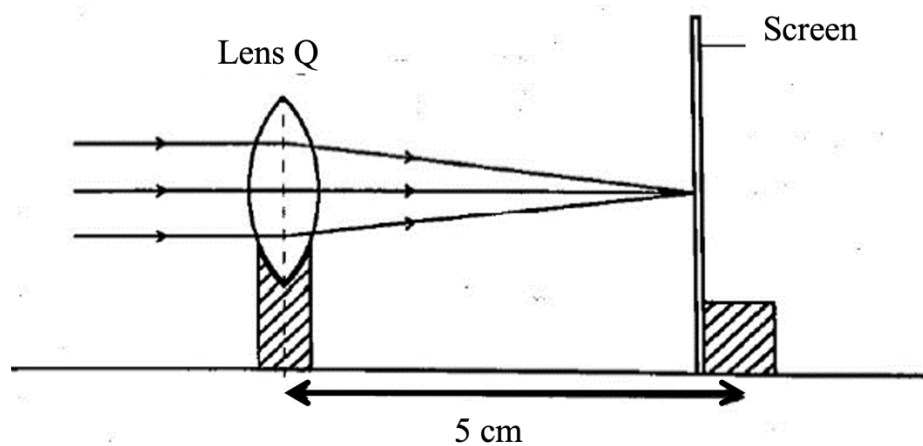

Diagram 11.2

- (a) Apakah yang dimaksudkan dengan panjang fokus?
What is meant by focal length?

[1 mark]

- (b) Perhatikan Rajah 11.1 dan Rajah 11.2, bandingkan jarak objek, ketebalan kanta dan panjang fokus. Nyatakan hubungan antara ketebalan kanta dengan panjang fokus. Namakan fenomena fizik yang terlibat.

Observe Diagram 11.1 and Diagram 11.2, compare the object distance, the thickness of the lens and the focal point. State the relationship between the thickness of the lens and the focal length. Name the physic phenomenon involved.

[5 marks]

- (c) Rajah 11.3 menunjukkan seorang ahli gemologi menggunakan satu kanta pembesar untuk menilai batu permata.

Diagram 11.3 shows a gemologist using a magnifying glass to evaluate a gemstone.

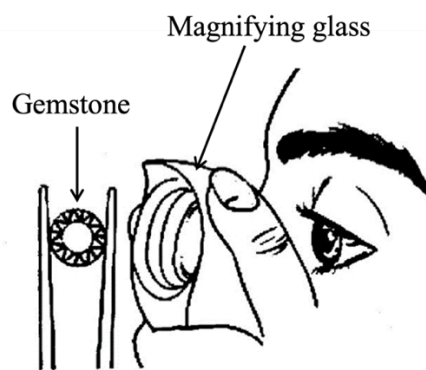

Diagram 11.3

Terangkan bagaimana ahli gemologi dapat memerhatikan imej yang besar dan maya.
Explain how the gemologist can observe a large and virtual image.

[4 marks]

- (d) Menggunakan kanta P dan kanta Q dalam Rajah 11.1 dan Rajah 11.2 anda dikehendaki merekacipta sebuah mikroskop majmuk yang boleh menilai batu-batu permata yang lebih kecil.

Using lens P and lens Q in Diagram 11.1 and Diagram 11.2, you are required to design a compound microscope which can be used to evaluate smaller gemstones.

Nyatakan dan terangkan pengubahsuaian anda berdasarkan aspek-aspek berikut:
State and explain your modification based on the following aspects:

- Kanta yang akan dipilih sebagai kanta objektif dan kanta mata.
Lens to be chosen as objective lens and eyepiece lens.
- Jarak objek bagi kanta objektif.
The object distance of the objective lens.
- Jarak objek bagi kanta mata.
The object distance of the eyepiece lens.
- Jarak antara kanta objektif dan kanta mata
The distance between the objective lens and the eyepiece lens.

[10 marks]

TOTAL 20 marks

SPM 2022

- 7 Rajah 7.1 menunjukkan lintasan sinar cahaya yang merambat suatu prisma kaca. Indeks biasan prisma kaca ialah 1.49.

Diagram 7.1 shows a ray path propagates a glass prism. The refractive index of the glass prism is 1.49.

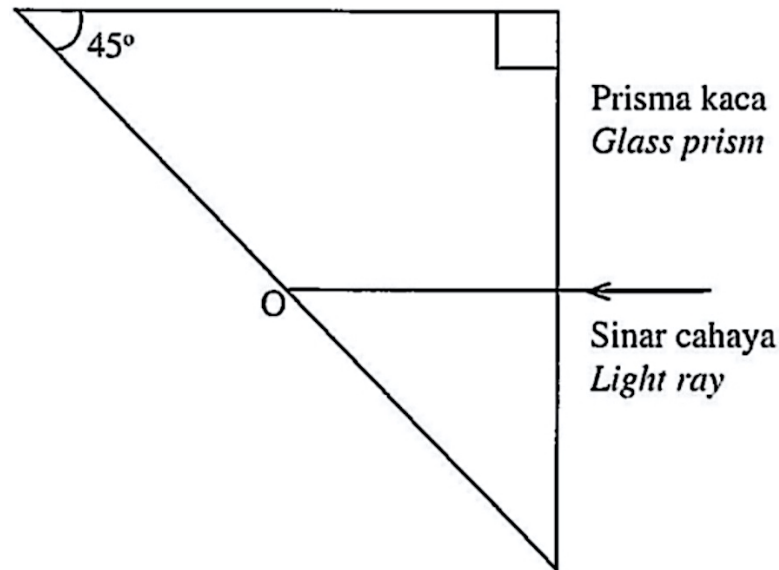

Rajah 7.1 / Diagram 7.1

- (a) Apakah maksud indeks biasan?
What is the meaning of refractive index?

.....
[1 mark]

- (b) (i) Hitung sudut genting prisma kaca itu.
Calculate the critical angle of the glass prism.

[2 marks]

- (ii) Pada Rajah 7.1, lukiskan lintasan sinar cahaya selepas titik O.
On Diagram 7.1, draw the path of light ray after point O.

[1 mark]

- (c) Rajah 7.2 menunjukkan imej setitis embun diujung daun yang diambil menggunakan kanta makro untuk memfokuskan objek jarak dekat.

Diagram 7.2 shows an image of a drop of dew at the tip of the leaf taken using macro lens to focus a close range object.

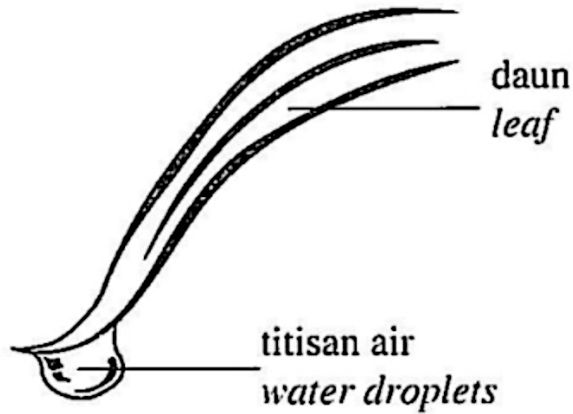

Rajah 7.2 / Diagram 7.2

Jadual 1 menunjukkan ciri-ciri bagi kanta P, Q dan R.

Table 1 shows the characteristics of lens P, Q and R.

Kanta Lens	Panjang fokus Focal length	Diameter kanta Diameter of lens
P	90.0 mm	Besar <i>Big</i>
Q	35.0 mm	Besar <i>Big</i>
R	90.0 mm	Kecil <i>Small</i>

Jadual 1 / Table 1

Berdasarkan Jadual 1, nyatakan ciri-ciri kesesuaian kanta makro. Berikan sebab.

Based on Table 1, state the suitable characteristics of a macro lens. Give a reason.

- (i) Panjang fokus kanta
Focal length of the lens

.....
[1 mark]

Sebab
Reason

.....
[1 mark]

(ii) Diameter kanta
Diameter of the lens

..... [1 mark]

Sebab
Reason

..... [1 mark]

(d) Berdasarkan jawapan anda di 7(c)(i) dan 7(c)(ii), tentukan kanta yang paling sesuai.
Based on the answer in 7(c)(i) and 7(c)(ii), determine the most suitable lens.

..... [1 mark]

TOTAL 9 marks

SPM 2023

- 3 Rajah 3 menunjukkan sebahagian daripada rajah sinar bagi kanta cembung.
Diagram 3 shows part of the ray diagram for a convex lens.

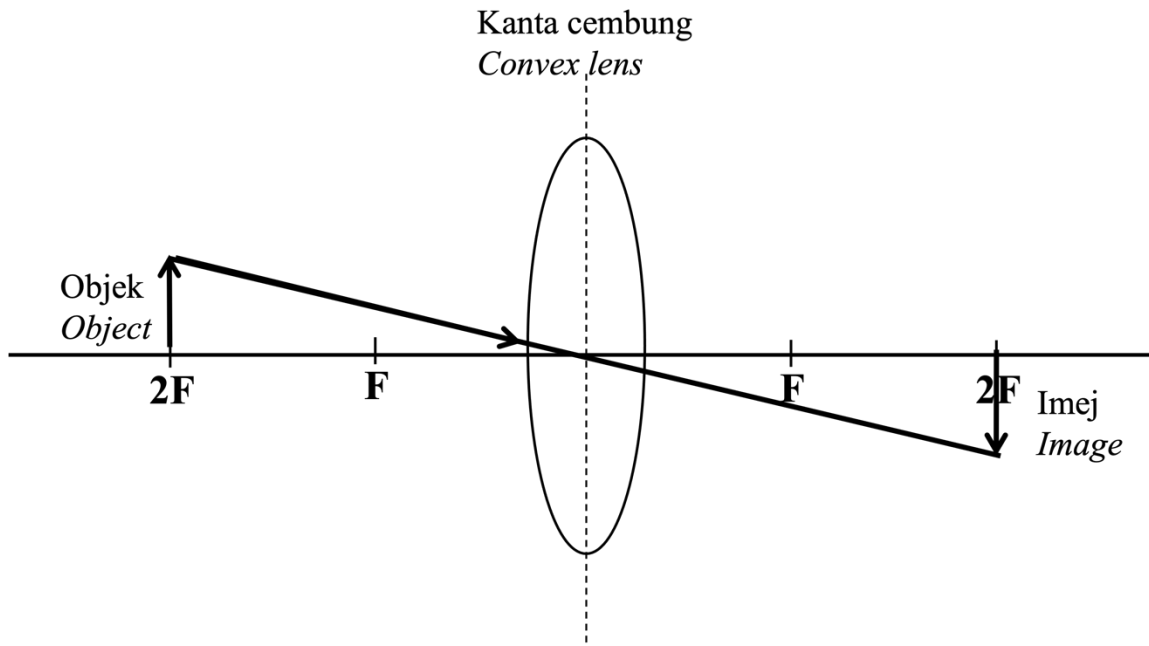

Rajah 3 / Diagram 3

- (a) Apakah nama lain bagi kanta cembung?
What is another name for convex lens?
-
- [1 markah / mark]
- (b) Lengkapkan Rajah 3 dengan melukis **satu** sinar cahaya lain untuk menunjukkan pembentukan imej tersebut.
*Complete Diagram 3 by drawing another **one** light ray to show the formation of the image.*
- [1 markah / mark]
- (c) Kanta dalam Rajah 3 ditukar kepada kanta yang lebih tebal.
The lens in Diagram 3 is changed to a thicker lens.
- (i) Apakah yang berlaku kepada panjang fokus?
What happens to the focal length?

.....

[1 markah / mark]

- (ii) Nyatakan perubahan kepada saiz imej jika objek kekal berada pada kedudukan yang sama.
State the change of the size of image if the object remains at the same position.

.....
[1 markah / mark]

- (d) Satu objek berada pada jarak 12 cm dari pusat optik kanta.
Satu imej nyata terbentuk pada jarak 9 cm.
Hitung pembesaran linear.
*An object is placed at a distance of 12 cm from the optical centre of the lens.
A real image is formed at a distance of 9 cm.
Calculate the linear magnification.*

[2 markah / marks]

TOTAL 6 marks

SPM 2024

- 11 Rajah 10.1 dan Rajah 10.2 menunjukkan sinar cahaya dengan sudut tuju, $i = 60^\circ$ merambat dari udara ke blok S dan blok T.
Diagrams 10.1 and 10.2 show light rays with an angle of incidence, $i = 60^\circ$ propagating from the air to block S and block T.

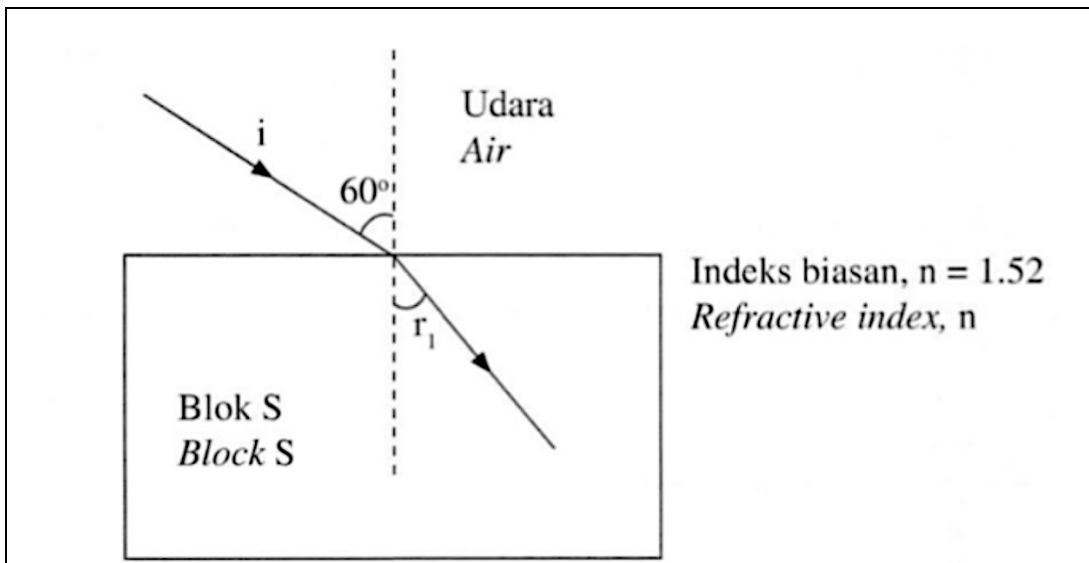

Rajah 10.1 / Diagram 10.1

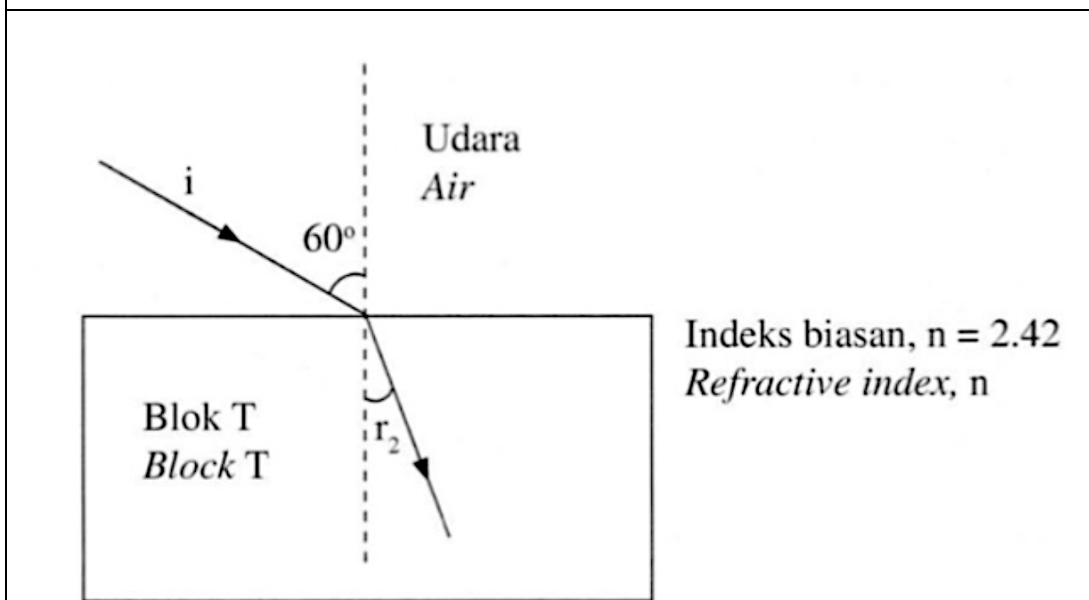

Rajah 10.2 / Diagram 10.2

- (a) Berdasarkan Rajah 10.1, nyatakan fenomena cahaya yang berlaku.
Based on Diagram 10.1, state the phenomenon of light that occurs.

[1 markah / mark]

- (b) Perhatikan Rajah 10.1 dan Rajah 10.2, bandingkan,
Observe Diagrams 10.1 and 10.2, compare,
- (i) sudut biasan
angle of refraction
 - (ii) ketumpatan optik
optical density
 - (iii) halaju cahaya yang melalui blok
the velocity of light passing through the block

[3 markah / marks]

- (c) Berdasarkan jawapan anda di 11(b), deduksikan hubungan antara
Based on your answer in 11(b), deduce the relationship between
- (i) indeks biasan dengan ketumpatan optik
refractive index and the optical density
 - (ii) indeks biasan dengan halaju cahaya yang melalui medium
refractive index and the velocity of light passing through the medium

[2 markah / marks]

- (d) Rajah 10.3 menunjukkan sekeping duit syiling berada dalam gelas berisi air.
Diagram 10.3 shows a coin in a glass filled with water.

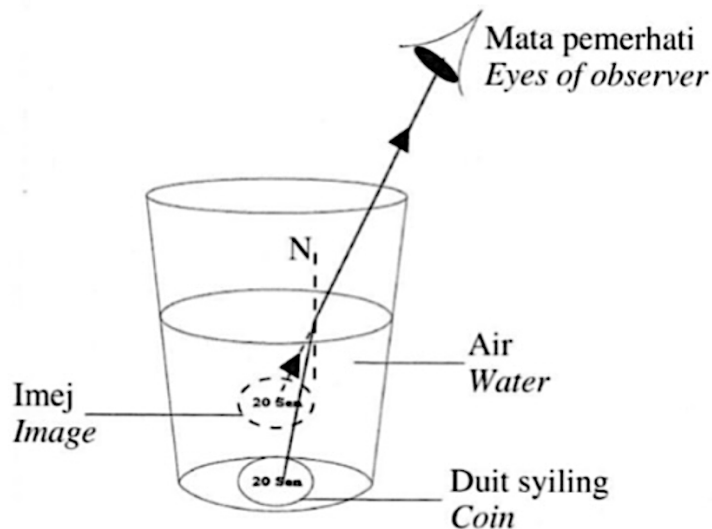

Rajah 10.3 / Diagram 10.3

Terangkan mengapa pemerhati melihat kedudukan duit syiling lebih dekat dengan permukaan air.

Explain why the observer sees the position of the coin closer to the surface of the water

[4 markah / marks]

- (e) Rajah 10.4 menunjukkan potongan gentian optik plastik yang digunakan dalam endoskop untuk melihat bahagian dalam tubuh manusia. Endoskop dilengkapi dengan kamera yang membolehkan doktor melihat imej yang diambil oleh kamera pada skrin. *Diagram 10.4 shows a piece of plastic optical fiber used in an endoscope to see the internal part of human body. The endoscope is equipped with a camera that allows the doctor to see the images taken by the camera on the screen.*

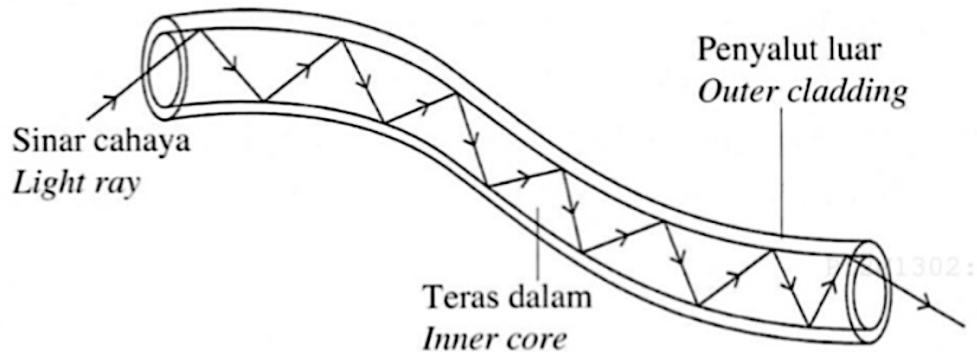

Rajah 10.4 / Diagram 10.4

Anda dikehendaki memberi cadangan untuk meningkatkan kecekapan gentian optic tersebut dan menghasilkan imej yang lebih jelas berdasarkan aspek kelenturan, indeks biasan teras dalam dan penyalut luar, ketulenan teras dalam dan bahan teras dalam. Cadangkan sama ada gentian optik bentuk tunggal atau himpunan lebih sesuai digunakan dalam endoskop tersebut. Justifikasikan cadangan anda.

You are required to make recommendations to improve the efficiency of the optical fiber and produce a clearer image based on the aspects of flexibility, refractive index of the inner core and outer cladding, purity of the inner core and inner core material.

Suggest whether single or bundled form optical fibers is more suitable to be used in the endoscope. Justify your suggestion.

[10 markah / marks]

TOTAL 20 marks

SOALAN F5

F5 BAB 1: DAYA & GERAKAN II

SPM 2021 (SET 1)

- 9 Diagram 9.1 shows a painting is hung on a wall with strings. The weight of the painting is 15 N. Each string can withstand a maximum force of 10 N.

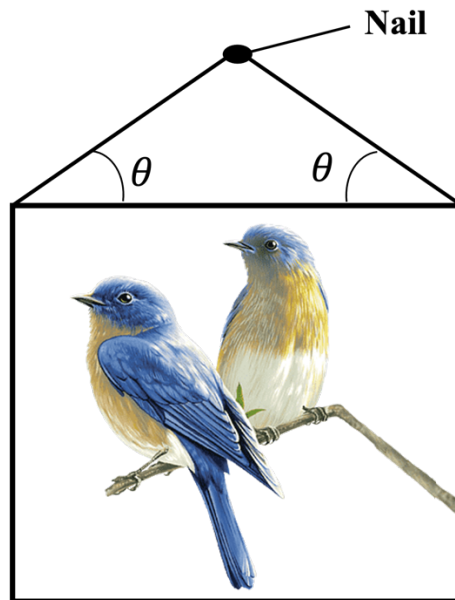

Diagram 9.1

- (a) What is the meaning of weight? [1 mark]
- (b) A few second after the painting is hung, it is found that the string of the painting is snapped. By using the value of the angle $\theta = 30^\circ$, calculate the tension of the string and resultant force. Explain why the string of the panting snaps. [4 marks]
- (c) The painting is broken when it drops from a height of 4 m. By ignoring the air resistance, calculate:
- (i) the time taken for the painting to reaches the floor [2 marks]
 - (ii) the velocity of the painting before it reaches the floor [2 marks]
 - (iii) State **one** reason why the painting is broken. [1 mark]

- (d) Table 1 shows four methods R, S, T and U to pull a lorry which is stuck in mud by two four-wheel drive vehicles.

<p>R</p>	 <p>Low maximum tension cable</p>
<p>S</p>	 <p>High maximum tension cable</p>
<p>T</p>	 <p>Low maximum tension cable</p>
<p>U</p>	 <p>High maximum tension cable</p>

Table 1

You are required to determine the most suitable method to pull the lorry that is stucked in mud effectively from the following aspects:

- Angle between the cables
- Types of cable
- Maximum tension of the cable
- Supported material below the tyre of the lorry

Explain the suitability of the aspects and determine the most suitable method to pull the lorry effectively. Give reasons for your choice.

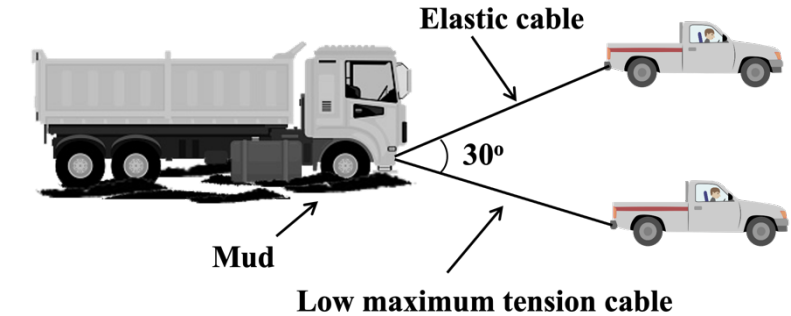
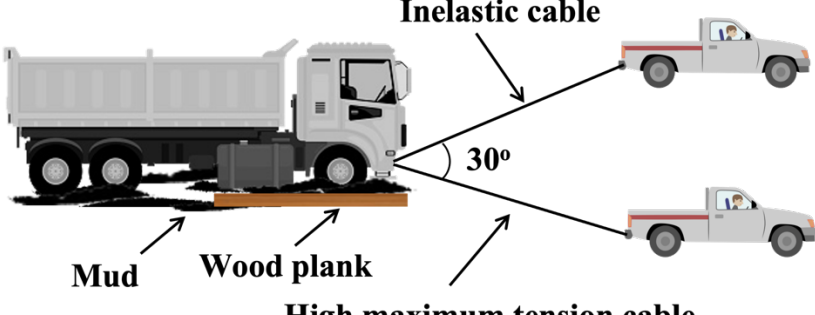
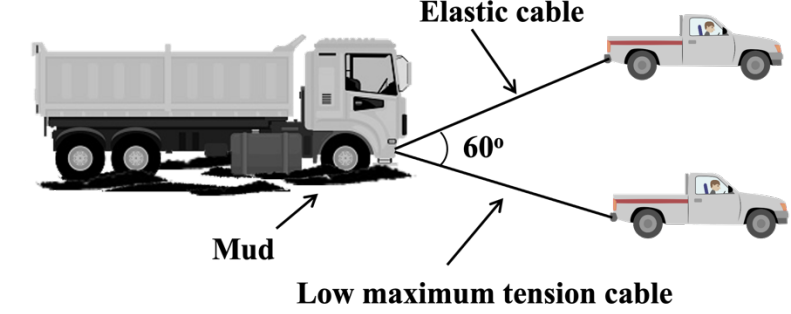
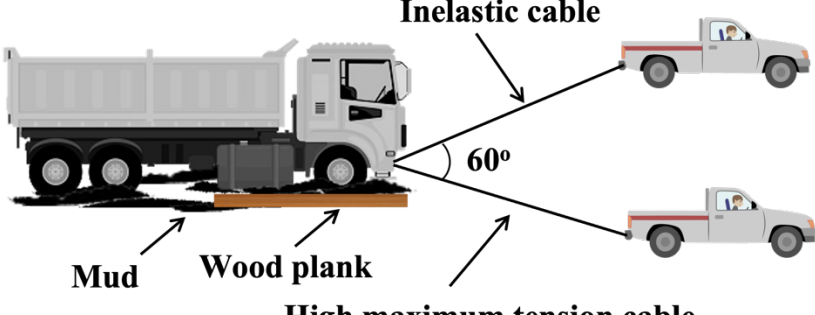
[10 marks]

TOTAL 20 marks

SPM 2021 (SET 2)

- 5 Rajah 5.1 menunjukkan sebuah bongkah P yang berada di atas permukaan kasar ditarik oleh pemberat Q melalui sebuah takal.
Daya paduan yang bertindak ke atas sistem itu adalah F.
*Diagram 5.1 shows a block P on a rough surface is pulled by a load Q through a pulley.
Resultant force acts on the system are F.*

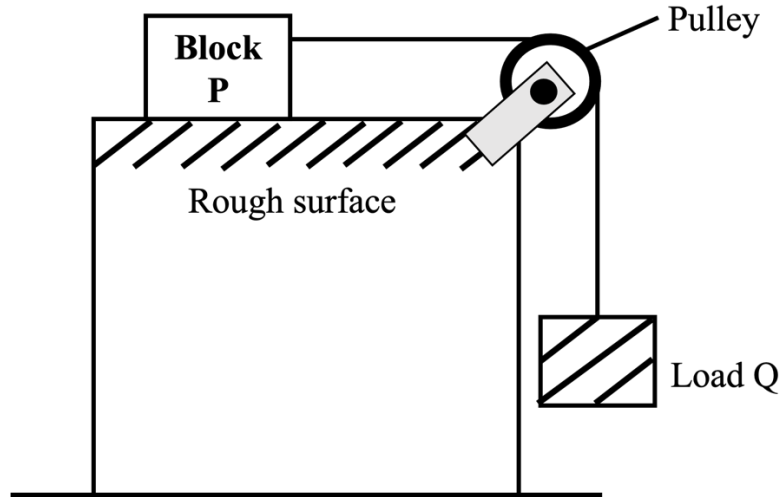

Diagram 5.1

- (a) Apakah maksud daya paduan?
What is the meaning of resultant force?
-
- [1 mark]
- (b) (i) Pada Rajah 5.1, tanda dan label daya geseran antara bongkah P dengan permukaan kasar.
On Diagram 5.1, mark and label the friction force between block P and the rough surface.
- [1 mark]
- (ii) Nyatakan keadaan gerakan bongkah P dan pemberat Q jika daya paduan adalah sifar.
State the motion of block P and load Q if the resultant force is zero.

.....

.....

[2 marks]

- (c) Rajah 5.2 dan Rajah 5.3 menunjukkan sistem X dan sistem Y di atas permukaan licin dan ditarik oleh pemberat yang serupa.

Diagram 5.2 and Diagram 5.3 shows system X and system Y on smooth surface pulled by identical load.

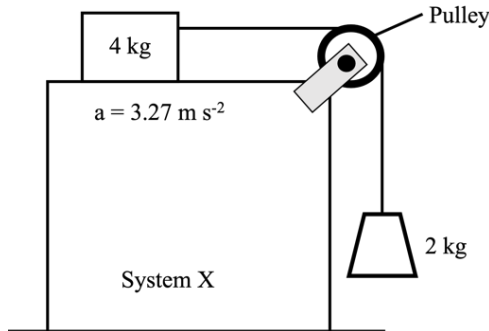

Diagram 5.2

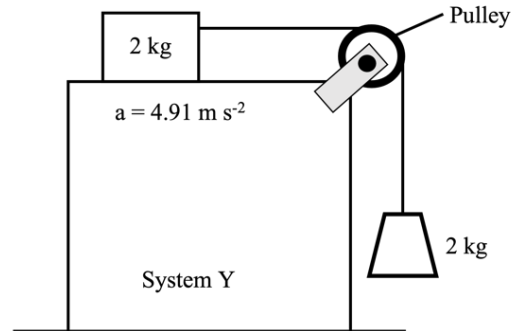

Diagram 5.3

Berdasarkan Rajah 5.2 dan Rajah 5.3,
Based on Diagram 5.2 and Diagram 5.3,

- (i) Bandingkan pecutan yang dihasilkan dalam sistem X dan sistem Y.
Compare the acceleration produced in system X and system Y.

..... [1 mark]

- (ii) Bandingkan jumlah jisim dalam sistem X dan sistem Y.
Compare the total mass in the system X and system Y.

..... [1 mark]

- (iii) Adakah terdapat perbezaan antara daya paduan yang bertindak dalam sistem X dan sistem Y.
Is there any difference between the resultant force acting on system X and system Y.

..... [1 mark]

- (d) Berdasarkan jawapan anda dalam (c)
Based on your answer in (c)

- (i) Berikan satu kesimpulan yang melibatkan daya, jisim dan pecutan.
Give one conclusion involving force, mass, and acceleration.

..... [1 mark]

- (ii) Namakan hukum fizik yang terlibat.
Name the physics law that involved.

..... [1 mark]

TOTAL 9 marks

SPM 2023

- 2 Rajah 2 menunjukkan graf daya, F melawan pemanjangan spring, X bagi spring keluli.
Diagram 2 shows a graph of force, F against the extension of spring, X of a steel spring.

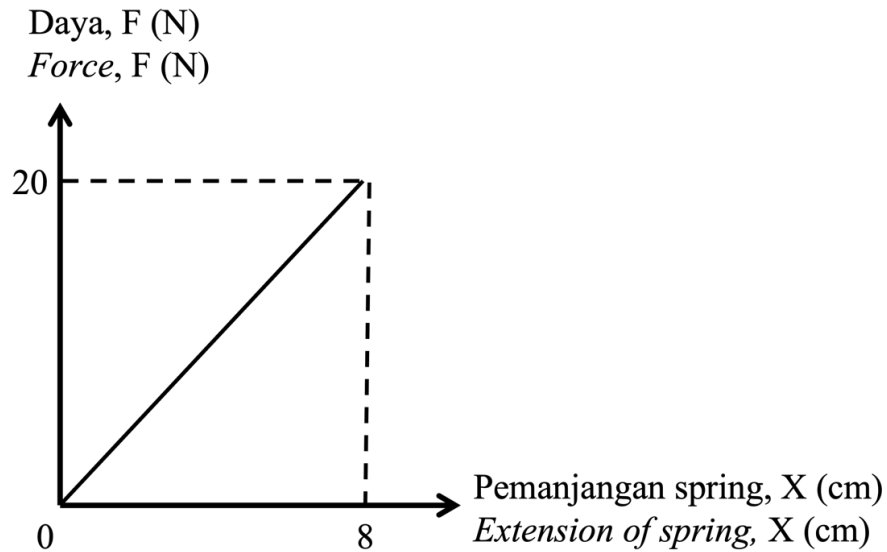

Rajah 2 / Diagram 2

- (a) Gariskan jawapan yang betul pada pernyataan di bawah.
Underline the correct answer to the statements below.

Hubungan antara daya dengan pemanjangan spring dapat diterangkan oleh (Hukum Ohm, Hukum Hooke)

The relationship between force and extension of spring can be explained by (Ohm's Law, Hooke's Law)

[1 markah / mark]

- (b) Berdasarkan Rajah 2, hitung pemalar spring keluli tersebut.
Based on Diagram 2, calculate the constant of the steel spring.

[2 markah / marks]

- (c) (i) Apakah yang akan berlaku kepada kecerunan graf dalam Raajah 2, jika spring keluli diganti dengan spring kuprum yang mempunyai ciri-ciri fizikal yang serupa?

What will happen to the gradient of the graph in Diagram 2, if the steel spring is replaced with a copper spring that has the same physical properties?

.....

[1 markah / mark]

- (ii) Beri satu sebab bagi jawapan anda di 2(c)(i).
Give one reason for your answer in 2(c)(i).

.....

[1 markah / mark]

TOTAL 5 marks

SPM 2024

- 2 Rajah 2 menunjukkan seorang budak lelaki sedang menggelongsor menuruni satu satah condong yang kasar.

Diagram 2 shows a boy sliding down a rough inclined plane.

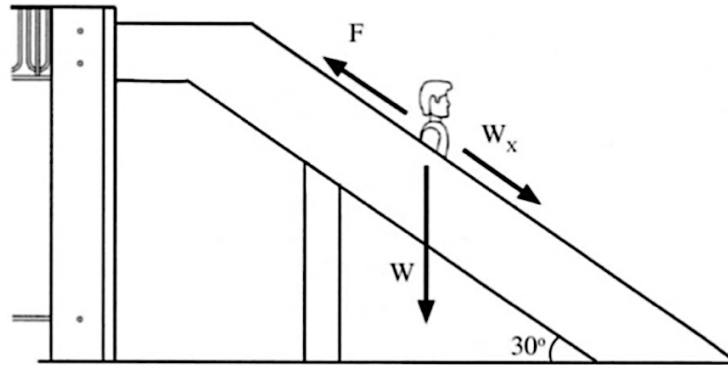

Rajah 2 / Diagram 2

- (a) Nyatakan daya, F yang menentang arah gerakan budak lelaki itu.
State the force, F that opposes the boy's direction of motion.

.....
[1 markah / mark]

- (b) Berat, W budak lelaki itu ialah 300 N.
Hitung komponen berat yang selari dengan satah condong, W_x .
*The weight, W of the boy is 300 N.
Calculate the component of the weight that is parallel to the inclined plane, W_x .*

[2 markah / marks]

- (c) Budak lelaki itu menggelongsor turun dengan halaju malar.
The boy slides down at a constant velocity.
(i) Nyatakan satu persamaan yang mengaitkan daya, F dengan W_x .
State one equation that relates the force, F to W_x .

.....
[1 markah / mark]

- (ii) Apakah konsep fizik yang terlibat di 2(c)(i).
What is the physics concept involved in 2(c)(i).

.....
[1 markah / mark]

TOTAL 5 marks

F5 BAB 2: TEKANAN

SPM 2021 (SET 1)

- 11 Diagram 11.1 shows a hydrofoil board that contains a surfboard with a hydrofoil that is attaches below it. When the board moves, the shape of the hydrofoil causes the board is lifted from the surface of the water due to the Bernoulli's principle.

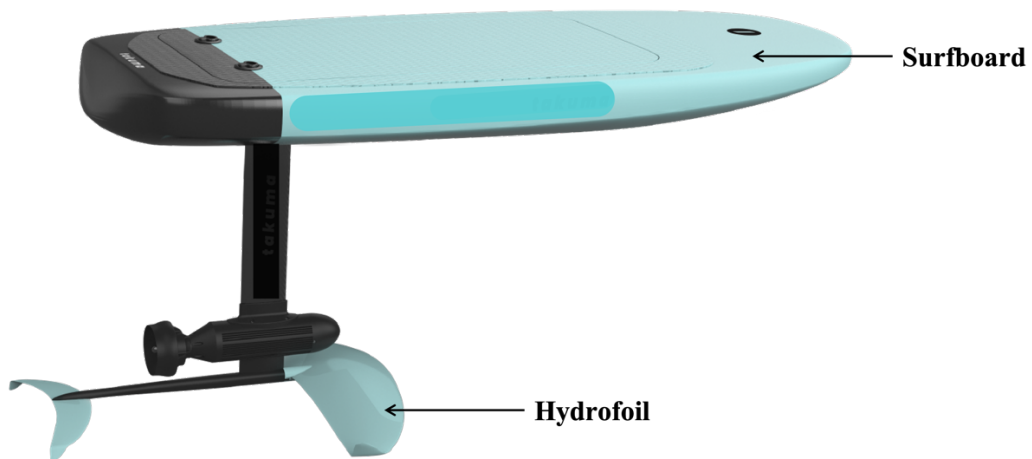

Diagram 11.1

- (a) State the Bernoulli's principle. [1 mark]
- (b) Explain how the hydrofoil can cause the board is lifted when the board moves forward. [4 marks]

(c) Diagram 11.2 shows a motorized surfboard without hydrofoil moves in 5 s.

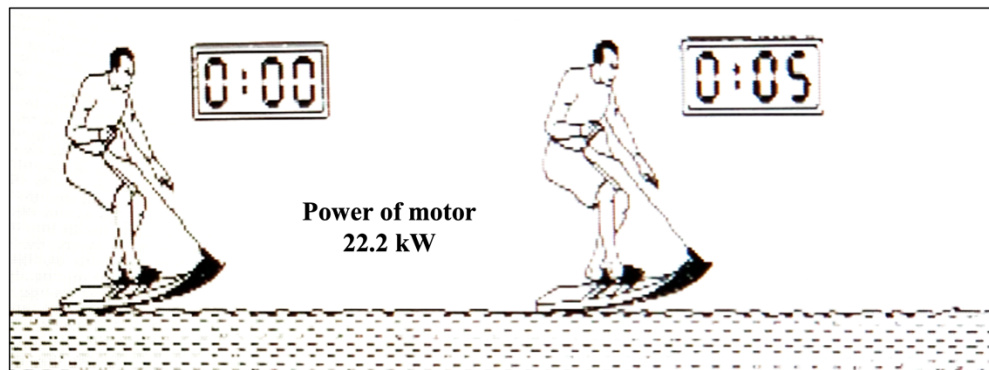

Diagram 11.2

Diagram 11.3 shows a motorized surfboard with hydrofoil moves in 5 s.

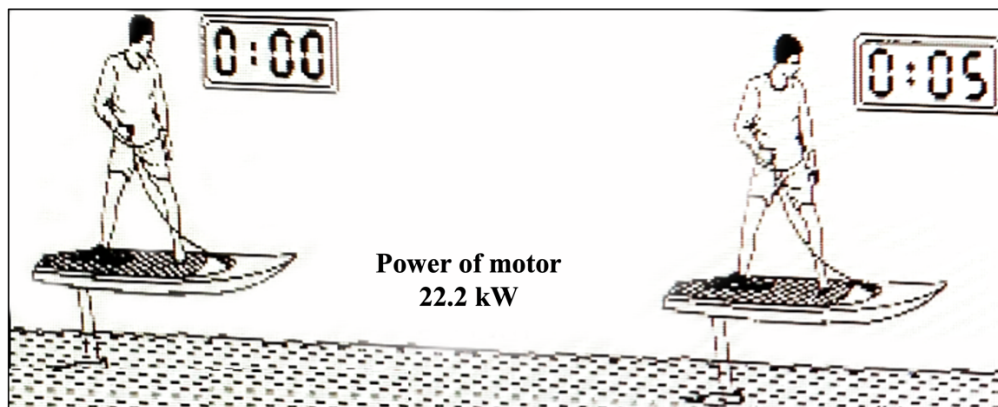

Diagram 11.3

Observe Diagram 11.2 and Diagram 11.3. Compare the height of the surfboard from the water surface, water friction acted on the surfboard and the speed of the surfboard.

Relate the height of the surfboard from the water surface and the water friction. Hence, deduce the relationship between the water friction and the speed of the surfboard.

[5 marks]

- (d) Diagram 11.4 shows a hydrofoil boat moves in the sea.

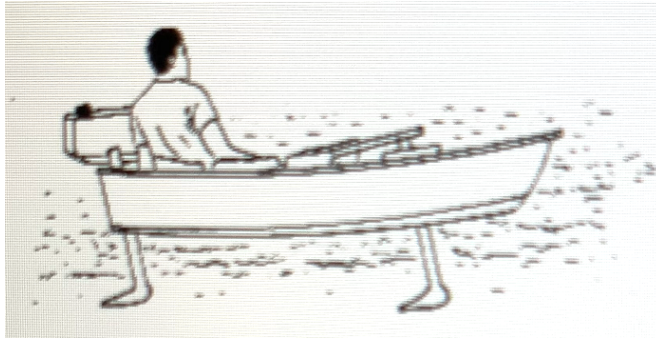

Diagram 11.4

You are required to design a hydrofoil boat that can move faster and carry more passengers at the same time and safely.

State and explain your suggestion based on the characteristics and the size of the boat, characteristics and the size of the hydrofoil, the power of engine used, and the number of the hydrofoil attached to the boat.

[10 marks]

TOTAL 20 marks

SPM 2021 (SET 2)

- 1 Rajah 1 menunjukkan satu tiub digunakan untuk mengalirkan air dari akuarium ke dalam baldi.

Diagram 1 shows a tube used to flow out the water from an aquarium into a pail.

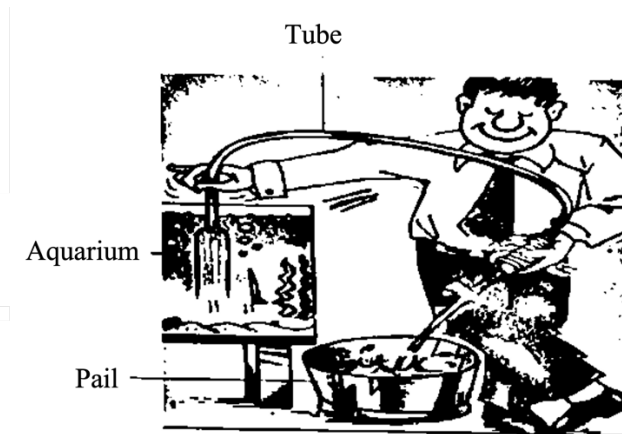

Diagram 1

- (a) Berdasarkan Rajah 1, namakan kaedah yang digunakan.
Based on Diagram 1, name the method used.

.....
[1 mark]

- (b) Apakah kuantiti fizik yang menyebabkan air mengalir keluar dari akuarium?
What is the physical quantity that causes water to flow out from the aquarium?

.....
[1 mark]

Gariskan perkataan yang betul.
Underline the correct word.

Kadar pemindahan air dapat ditingkatkan dengan
Rate of water transfer can be increased by

- (i) (mengurangkan, menambahkan) diameter tiub.
(reduce, increase) the diameter of the tube.

[1 mark]

- (ii) (merendahkan, meninggikan) kedudukan baldi.
(lower, higher) the position of the pail.

[1 mark]

TOTAL 4 marks

SPM 2022

- 1 Rajah 1 menunjukkan keputusan eksperimen bagi menentukan hubungan antara daya apungan, F_B dan kedalaman rod tenggelam di dalam air, d .
Diagram 1 shows a result of an experiment to determine the relationship between buoyant force, F_B and depth of rod immersed in water, d .

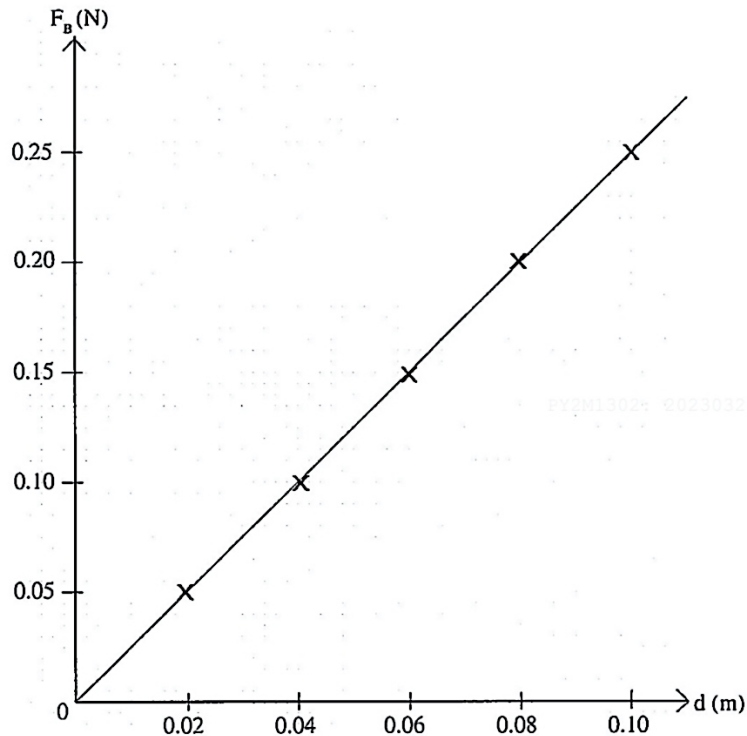

Rajah 1 / Diagram 1

- (a) Nyatakan jenis kuantiti fizik bagi daya apungan, F_B .
State the type of physical quantity for buoyant force, F_B .

.....
[1 mark]

- (b) Berdasarkan Rajah 1,
Based on Diagram 1,

- (i) Tandakan (\surd) bagi pembolehubah dimanupulasi dalam eksperimen tersebut.
Tick (\surd) the manipulated variable in the experiment.

Daya apungan, F_B
Buoyant force, F_B

kedalaman rod tenggelam di dalam air, d
depth of rod immersed in water, d

[1 mark]

- (ii) Tentukan nilai F_B apabila $d = 0.08$ m.
Tunjukkan bagaimana nilai F_B ditentukan pada graf dalam Rajah 1.
*Determine the value of F_B when $d = 0.08$ m.
Show hoe the value of F_B is determined on the graph in Diagram 1.*

$F_B = \dots\dots\dots$

[2 marks]

TOTAL 4 marks

- 6 Rajah 6 menunjukkan dua orang atlet sedang mendayung kayak P dan kayak Q yang serupa dengan berat yang sama iaitu 300 N. Kedua-dua kayak tersebut terapung di air sungai. Berat atlet X dan atlet Y masing-masing adalah 800 N dan 500 N.

Diagram 6 shows two athletes are rowing kayak P and Q which are identical with the same weight of 300 N. Both kayakers are floating in the river water. The weight of athlete X and athlete Y are 800 N and 500 N respectively..

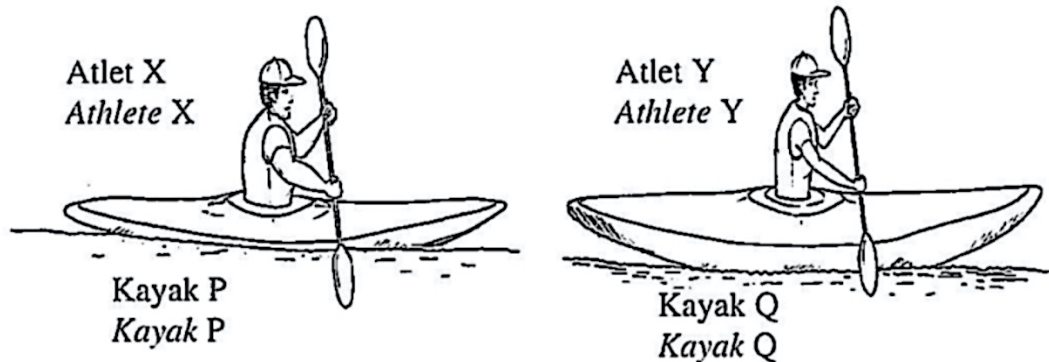

Rajah 6 / Diagram 6

- (a) Apakah maksud berat?
What is the meaning of weight?

..... [1 mark]

- (b) (i) Menggunakan konsep daya, nyatakan bagaimana kayak-kayak tersebut boleh terapung di permukaan air.
Using the concept of force, state how kayaks can float on the water surface

..... [1 mark]

- (ii) Kayak P telah menyesarkan sejumlah isipadu air sungai semasa terapung. Hitung isipadu air sungai yang disasarkan, V .
[ketumpatan air sungai, $\rho = 1000 \text{ kg m}^{-3}$]

Kayak P has displaced a certain volume of river water while floating. Calculate the volume of river water displaced, V . [density of river water, $\rho = 1000 \text{ kg m}^{-3}$]

$V = \dots\dots\dots \text{ m}^3$

[2 marks]

(c) Berdasarkan Rajah 6,
Based on Diagram 6,

(i) Kayak manakah menampung berat beban yang lebih besar?
Which kayak accommodate a larger load?

.....
[1 mark]

(ii) Kayak manakah yang menyesarkan lebih banyak isipadu air sungai?
Which kayak displaces more volume of river water?

.....
[1 mark]

(iii) Kayak manakah yang mempunyai daya apungan yang lebih besar?
Which kayak has greater buoyant force?

.....
[1 mark]

(d) Menggunakan jawapan anda di 6(c), hubungkaitkan,
Using your answer in 6(c), relate,

(i) berat beban dengan isipadu air yang tersesar.
the weight of the load and volume of water displaced.

.....
[1 mark]

(ii) berat beban dengan daya apungan.
the weight of the load and the buoyant force.

.....
[1 mark]

TOTAL 9 marks

SPM 2023

- 10 Rajah 10.1 menunjukkan barometer Fortin untuk mengukur tekanan atmosfera.
Diagram 10.1 shows a Fortin barometer to measure atmospheric pressure.

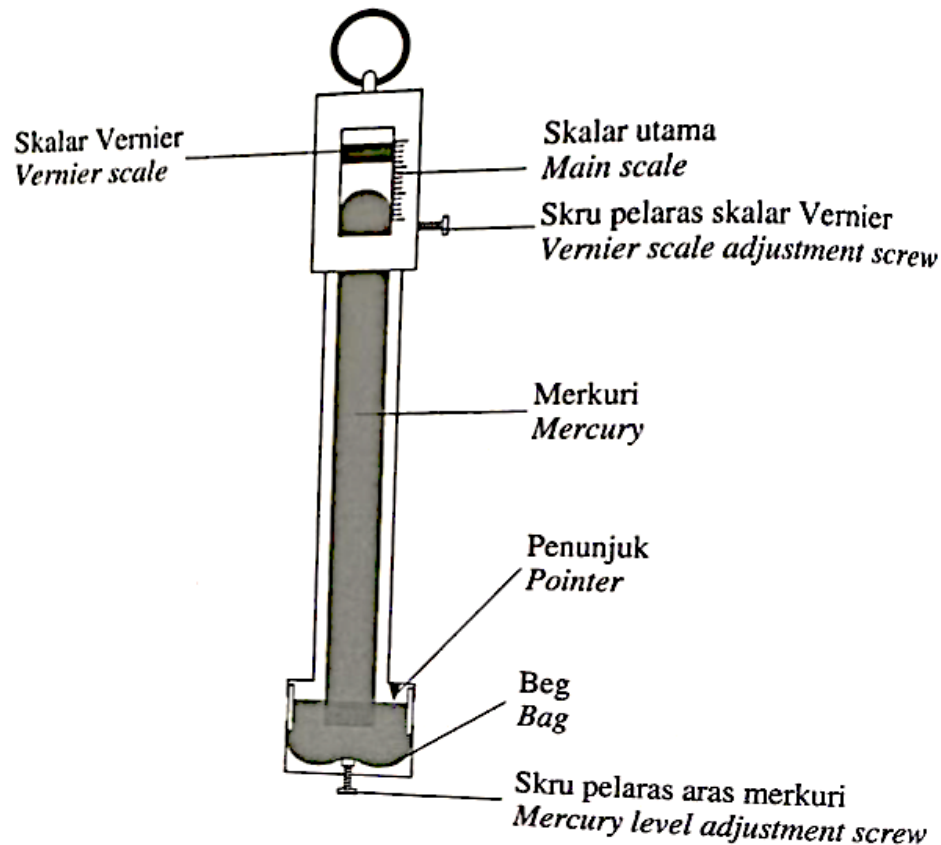

Rajah 10.1 / Diagram 10.1

- (a) Apakah maksud tekanan atmosfera?
What is meant by atmospheric pressure? [1 markah / mark]
- (b) (i) Terangkan mengapa merkuri digunakan dalam tiub kaca barometer Fortin
Explain why mercury is used in the glass tube of Fortin barometer? [3 markah / marks]
- (ii) Mengapakah skalar vernier digunakan dalam barometer Fortin?
Why vernier scale is used in Fortin barometer? [1 markah / mark]

- (c) Jadual 10 menunjukkan ciri-ciri komponen yang digunakan dalam barometer Fortin P, Q, R dan S.

Table 10 shows the characteristics of the components used in the Fortin Barometer, P, Q, R and S.

Barometer <i>Barometer</i>	Bahan beg <i>Bag material</i>	Bahan tiub pelindung <i>Protector tube material</i>	Bahan penunjuk <i>Pointer material</i>	Instrument tambahan <i>Additional instrument</i>
P	Plastik <i>Plastic</i>	Kaca <i>Glass</i>	Gading <i>Ivory</i>	Hidrometer <i>Hydrometer</i>
Q	Kulit <i>Leather</i>	Loyang <i>Brass</i>	Gading <i>Ivory</i>	Termometer <i>Thermometer</i>
R	Kulit <i>Leather</i>	Loyang <i>Brass</i>	Keluli <i>Steel</i>	Hidrometer <i>Hydrometer</i>
S	Plastik <i>Plastic</i>	Kaca <i>Glass</i>	Keluli <i>Steel</i>	Termometer <i>Thermometer</i>

Jadual 10 / Table 10

Anda dikehendaki untuk mengkaji ciri-ciri barometer Fortin dalam Jadual 10.

Jelaskan kesesuaian setiap ciri barometer Fortin tersebut.

Tentukan barometer yang paling sesuai boleh digunakan untuk mengukur tekanan atmosfera dengan berkesan.

Berikan alasan untuk pilihan anda.

You are required to study the characteristic of the Fortin barometer in Table 10.

Explain the suitability of each characteristic of the Fortin barometer.

Determine the most appropriate barometer that can be used to measure atmospheric pressure effectively.

Give reasons for your choice.

[10 markah / marks]

- (d) Tekanan atmosphere di permukaan laut ialah 76 cm Hg, manakala tekanan atmosfera di puncak sebuah gunung ialah 30 cm Hg.
Ketumpatan merkuri ialah $1.36 \times 10^4 \text{ kg m}^{-3}$ dan ketumpatan purata udara ialah 1.3 kg m^{-3} .

The atmospheric pressure at the surface of sea level is 76 cm Hg, while the atmospheric pressure at the top of a mountain is 30 cm Hg.

The density of mercury is $1.36 \times 10^4 \text{ kg m}^{-3}$ and the average density of air is 1.3 kg m^{-3} .

- (i) Hitung tekanan atmosfera di permukaan laut dalam unit milibar (mbar).

(1 milibar = 1 hPa)

Calculate the atmospheric pressure at sea level in units of millibars (mbar).

(1 millibar = 1 hPa)

[3 markah / marks]

- (ii) Hitung ketinggian gunung tersebut dalam unit meter.

Calculate the height of the mountain in the unit of meter.

[2 markah / marks]

TOTAL 20 marks

SPM 2024

- 4 Rajah 3 menunjukkan sebuah hidrometer berjisim 0.028 kg terapung dalam larutan garam.
Diagram 3 shows a hydrometer with a mass of 0.028 kg floating in a salt solution.

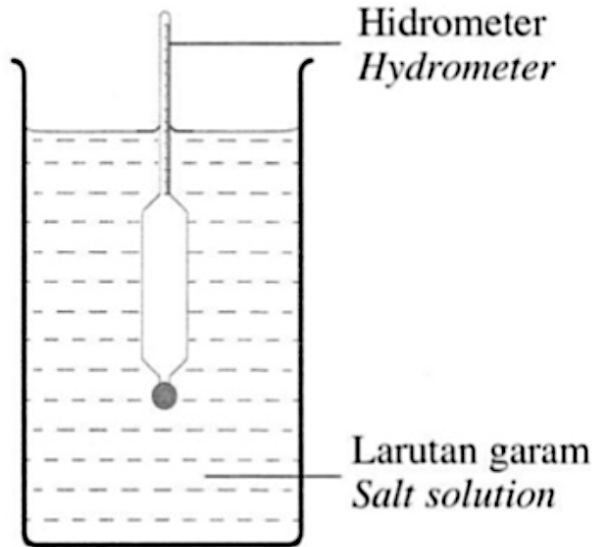

Rajah 3 / Diagram 3

- (a) Nyatakan kegunaan hidrometer.
State the use of a hydrometer.

.....
[1 markah / mark]

- (b) Ketumpatan larutan garam dalam Rajah 3 adalah 1020 kg m^{-3} .
The density of the salt solution in Diagram 3 is 1020 kg m^{-3} .

- (i) Hitung berat hidrometer.
Calculate the weight of the hydrometer.

[2 markah / marks]

- (ii) Nyatakan daya apungan yang bertindak ke atas hidrometer.
State the buoyant force that acted on the hydrometer.

.....
[1 markah / mark]

- (iii) Tentukan isipadu larutan garam yang disesarkan oleh hidrometer.
Determine the volume of salt solution displaced by the hydrometer.

[2 markah / marks]

- (c) Larutan garam dalam Rajah 3 digantikan dengan gliserin yang berketumpatan 1260 kg m^{-3} .

The salt solution in Diagram 3 is replaced by glycerin with a density of 1260 kg m^{-3} .

- (i) Apakah yang berlaku kepada kedalaman bahagian hydrometer yang tenggelam?
What happens to the depth of the submerged part of the hydrometer?

.....
[1 markah / mark]

- (ii) Jelaskan jawapan anda di 4(c)(i).
Explain your answer in 4(c)(i).

.....
[1 markah / mark]

TOTAL 9 marks

F5 BAB 3: KEELEKTRIKAN

SPM 2021 (SET 1)

10 Diagram 10.1 shows an electric cooker labelled as 1000 W 240 V.



Diagram 10.1

- (a) What is the meaning of electric current? [1 mark]
- (b) Diagram 10.2 shows the cross-section of the heating element in the electric cooker.

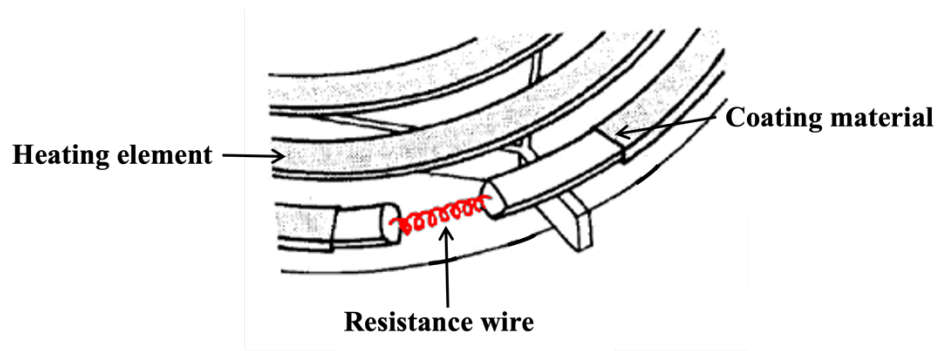

Diagram 10.2

- (i) Calculate the resistance of the resistance wire. [3 marks]
- (ii) The electric current flow through the resistance wire is 4.2 A. Calculate the power produced by the resistance wire. [2 marks]

- (c) Diagram 10.3 shows a pot is placed on top of the electric cooker.

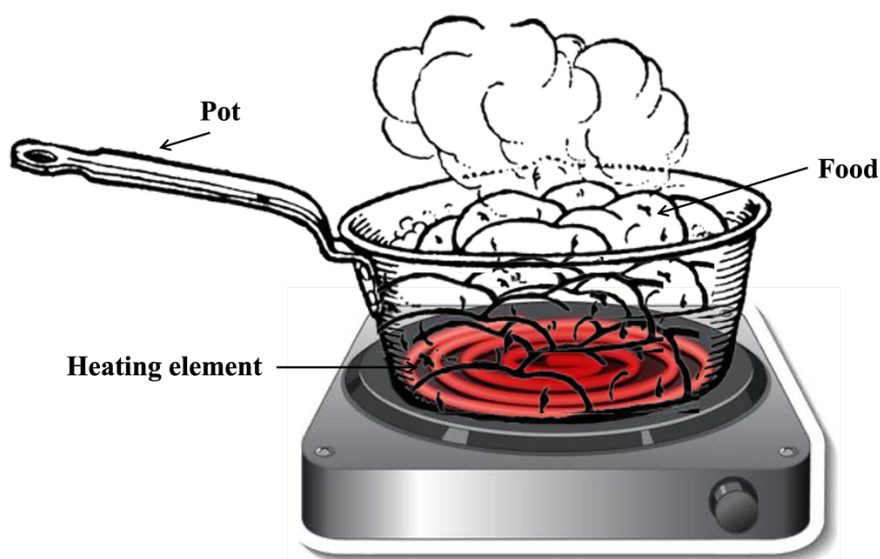

Diagram 10.3

Explain how the heating element of the electric cooker can be used to heat up the food in the pot.

[4 marks]

- (d) The heating element in Diagram 10.2 does not last and needs longer time to heat up the food. Table 2 shows the characteristics of the four heating elements K, L, M and N.

Heating element	Shape of resistance wire	The resistivity of resistance wire	Material of resistance wire	Coating material
K	Straight	High	Aluminium	Steel
L	Coiled	High	Nichrome	Steel
M	Straight	Low	Nichrome	Copper
N	Coiled	Low	Aluminium	Copper

Table 2

Study each characteristic of the heating element and explain the suitability of each characteristic.

Determine the heating element that is lasting and can be heat up the food faster. Give the reason for your choice.

[10 marks]

TOTAL 20 marks

SPM 2022

- 10** Rajah 10.1 menunjukkan satu litar elektrik.
Diagram 10.1 shows an electrical circuit.

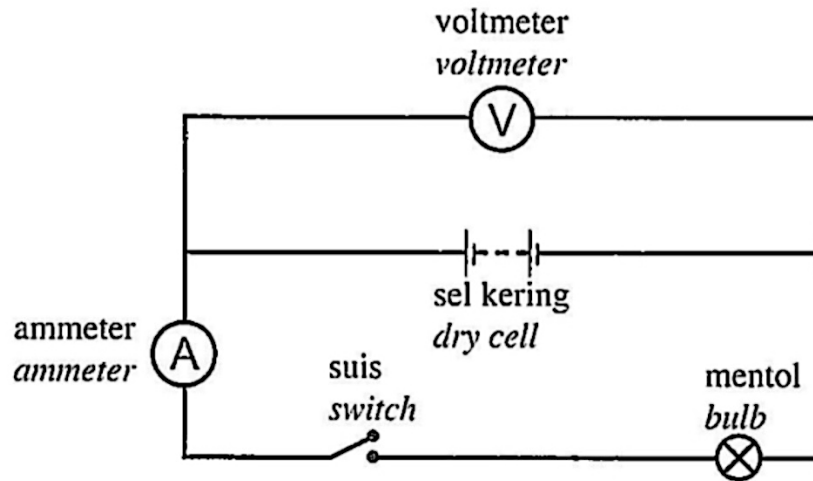

Rajah 10. 1 / Diagram 10.1

- (a) Nyatakan fungsi voltmeter.
State the function of voltmeter.

[1 mark]

- (b) Berdasarkan Rajah 10.1,
Based on Diagram 10.1,

- (i) apakah yang berlaku kepada bacaan ammeter dan bacaan voltmeter apabila suis dihidupkan.
what happened to the ammeter reading and voltmeter reading when the switch is turned on.

[2 marks]

- (ii) Jelaskan jawapan anda di **10(b)(i)**.
*Explain your answer in **10(b)(i)**.*

[2 marks]

- (c) Rajah 10.2 menunjukkan empat jenis litar elektrik, P, Q, R dan S. Litar elektrik itu terdiri daripada empat biji sel kering yang serupa dan dua jenis sumber cahaya iaitu tiga mentol berfilamen dan tiga Diod Pemancar Cahaya (LED). Daya gerak elektrik (d.g.e) bagi setiap sel kering dan kadar kuasa setiap sumber cahaya adalah sama.

Diagram 10.2 shows four types of electric circuits, P, Q, R and S. The electric circuits consist of four identical dry cells and two types of light sources which are three filament bulbs and three Light Emitting Diodes (LED). The electromotive force (e.m.f) for each dry cell and the power of each light source is the same.

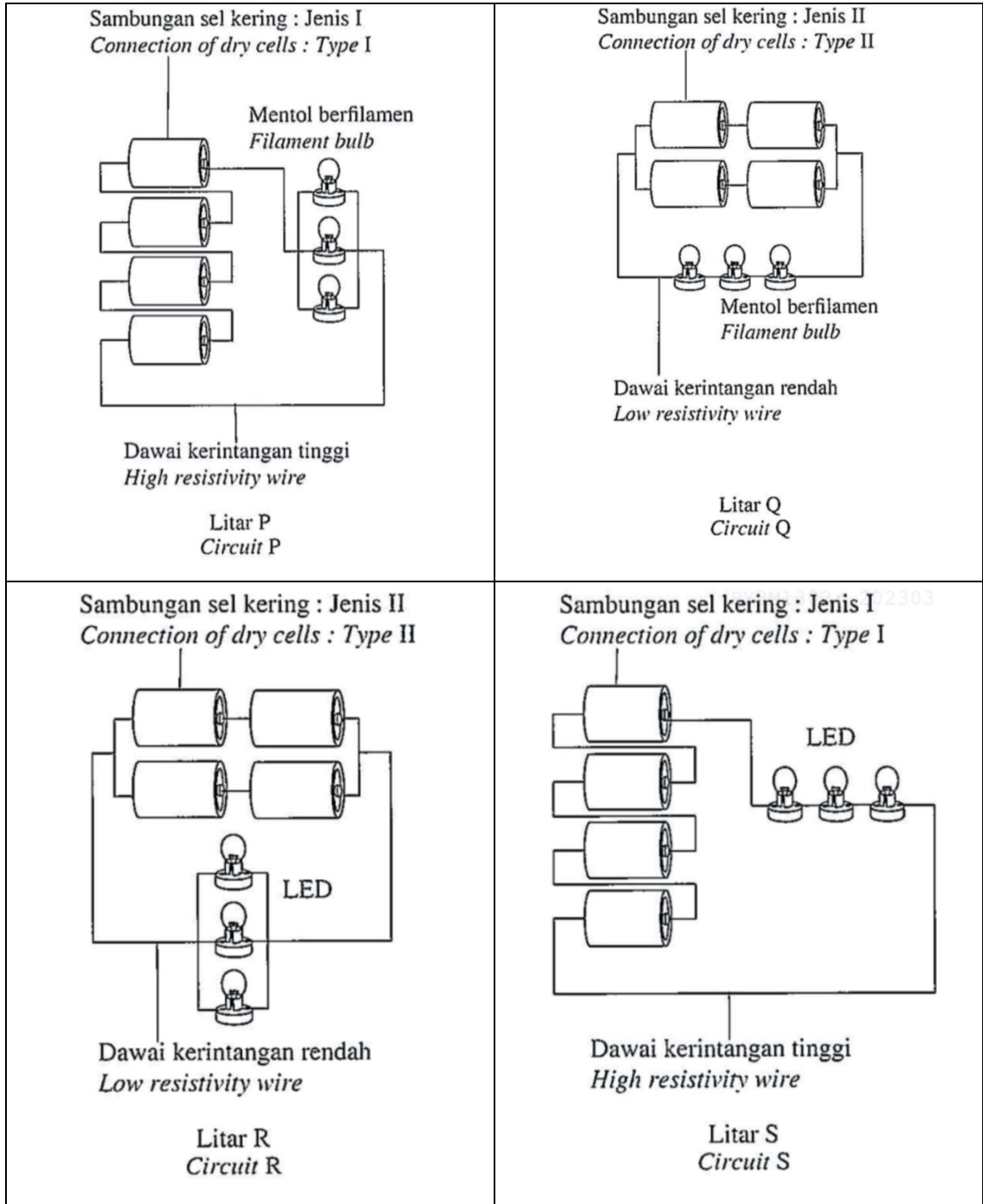

Rajah 10.2 / Diagram 10.2

Kaji dan tentukan litar elektrik yang paling sesuai untuk menghasilkan cahaya yang lebih cerah dan sumber cahaya yang tidak mudah terbakar.

Study and determine the most suitable electric circuit that produce brighter light and is not easily flammable light source.

- (i) Terangkan kesesuaian bagi setiap spesifikasi.

Explain the suitability for each specification.

[8 marks]

- (ii) Pilih litar yang paling sesuai. Berikan sebab untuk pilihan anda.

Choose the most suitable circuit. Give reasons for your choice.

[2 marks]

- (d) Rajah 10.3 menunjukkan satu litar elektrik yang mengandungi dua sel kering 9 V setiap satu, ammeter dan satu kipas mini. Rintangan dalam sel kering ialah 0.5 Ohm dan rintangan kipas mini ialah 60 Ohm.

Diagram 10.3 shows an electric circuit containing two 9 V dry cell each, an ammeter and a mini fan. The internal resistance of each dry cell is 0.5 Ohm and the resistance of the mini fan is 60 Ohm.

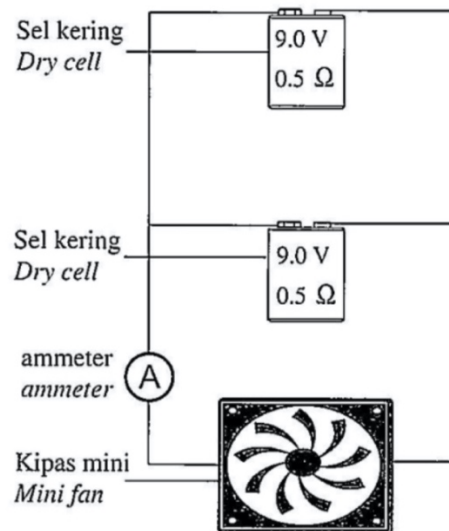

Rajah 10.3 / Diagram 10.3

Berdasarkan Rajah 10.3, hitung

Based on Diagram 10.3, calculate

- (i) rintangan dalam berkesan bagi sel-sel kering.

the effective internal resistance for dry cells.

- (ii) bacaan ammeter.

the reading of the ammeter.

[5 marks]

TOTAL 20 marks

SPM 2023

- 8 Rajah 8.1 menunjukkan satu litar elektrik yang mengandungi beberapa sel kering dengan daya gerak elektrik, $\epsilon = 6 \text{ V}$ dan rintangan dalam, $r = 2 \Omega$.
Diagram 8.1 shows an electric circuit containing several dry cells with electromotive force, $\epsilon = 6 \text{ V}$ and internal resistance, $r = 2 \Omega$.

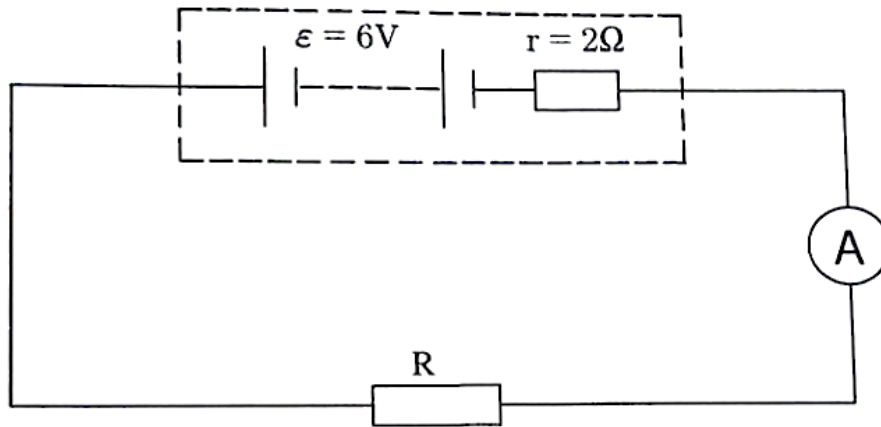

Rajah 8.1 / Diagram 8.1

- (a) Apakah maksud daya gerak elektrik?
What is meant by electromotive force?

.....
[1 markah / mark]

- (b) Hitung bacaan ammeter dalam Rajah 8.1.
Calculate the ammeter reading in Diagram 8.1.

[2 markah / marks]

- (c) Rajah 8.2 menunjukkan sebuah lampu suluh yang menggunakan sebiji bateri.
Diagram 8.2 shows a torch light that uses a battery.

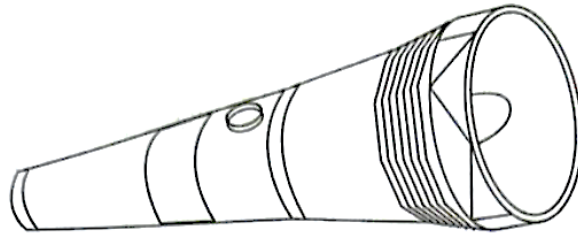

Rajah 8.2 / Diagram 8.2

Cahaya yang terhasil daripada lampu suluh dalam Rajah 8.2 malap.

Nyatakan pengubahsuaian yang boleh dilakukan terhadap lampu suluh tersebut supaya dapat menghasilkan cahaya lebih terang berdasarkan aspek-aspek berikut:

The light produced by the torch light in Diagram 8.2 is dim.

State the modifications that can be made to the torch light so that it can produce brighter light based on the following aspects:

- (i) bilangan bateri
the number of the batteries

.....
 [1 markah / mark]

Sebab
Reason

.....
 [1 markah / mark]

- (ii) susunan bateri
the arrangement of the batteries

.....
 [1 markah / mark]

Sebab
Reason

.....
 [1 markah / mark]

- (iii) jenis mentol
the type of bulb

.....
 [1 markah / mark]

Sebab
Reason

.....
 [1 markah / mark]

TOTAL 9 marks

SPM 2024

- 7 Rajah 6 menunjukkan dawai filamen dengan kerintangan, $\rho = 5.6 \times 10^{-8} \Omega \text{ m}$ dalam sebiji mentol.

Diagram 6 shows a filament wire with resistivity, $\rho = 5.6 \times 10^{-8} \Omega \text{ m}$ in a bulb.



Rajah 6 / Diagram 6

- (a) Nyatakan maksud kerintangan.
State the meaning of resistivity.

.....
[1 markah / mark]

- (b) Jadual 1 menunjukkan ciri dawai filamen yang digunakan dalam mentol tersebut.
Table 1 shows the characteristics of the filament wire used in the bulb.

Panjang dawai filamen <i>Length of filament wire</i>	0.54 m
Luas keratan rentas dawai filamen <i>Cross-sectional area of filament wire</i>	$1.25 \times 10^{-5} \text{ cm}^2$
Kerintangan dawai filamen <i>Resistivity of filament wire</i>	$5.6 \times 10^{-8} \Omega \text{ m}$

Jadual 1 / Table 1

Hitung rintangan dawai filamen tersebut dalam unit SI.
Calculate the resistance of the filament wire in SI unit.

[3 markah / marks]

- (c) Jadual 2 menunjukkan nilai kuasa dan nilai kerintangan bagi mentol, J, K dan L.
Table 2 shows the power and resistivity values for bulbs, J, K and L.

Mentol <i>Bulb</i>	Kuasa (W) <i>Power (W)</i>	Kerintangan (Ω m) <i>Resistivity (Ω m)</i>
J	30	49×10^{-8}
K	40	100×10^{-8}
L	50	1.68×10^{-8}

Jadual 2 / Table 2

Berdasarkan Jadual 2, nyatakan ciri yang sesuai untuk menghasilkan mentol yang paling terang.

Based on Table 2, state the suitable characteristics to produce the brightest bulb.

- (i) Kuasa mentol
The power of the bulb

.....

Sebab
Reason

.....

[2 markah / marks]

- (ii) Kerintangan dawai filamen
Resistivity of the filament wire

.....

Sebab
Reason

.....

[2 markah / marks]

- (d) Berdasarkan jawapan di 7(c), pilih mentol yang paling terang.
Based on the answer in 7(c), choose the brightest bulb.

.....

[1 markah / mark]

TOTAL 9 marks

F5 BAB 4: KEELEKTROMAGNETAN

SPM 2021 (SET 1)

- 6 Diagram 6.1(a) and Diagram 6.1(b) show the copper wire in the magnetic field swings when the current flows through it.

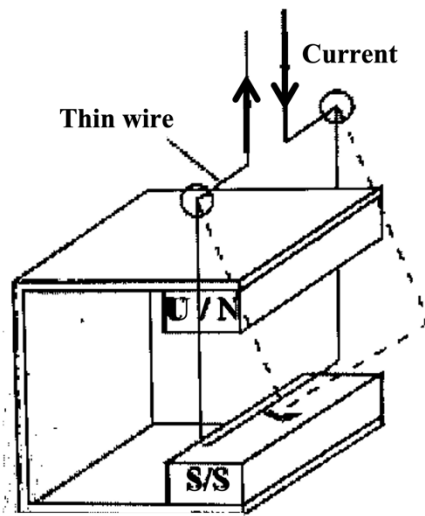

Diagram 6.1(a)

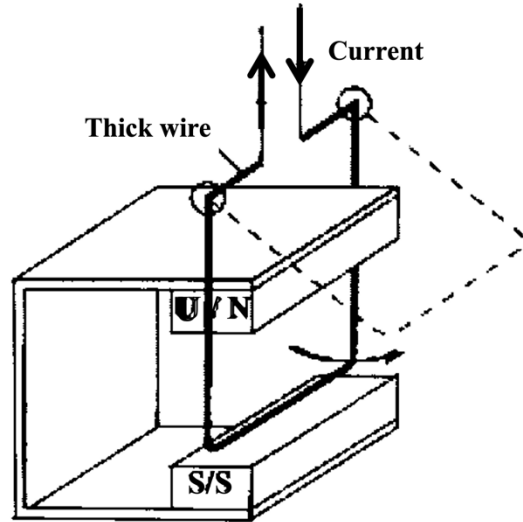

Diagram 6.1(b)

- (a) Name the rule that is used to determine the direction of the copper wire swing.

..... [1 mark]

- (b) Observe Diagram 6.1(a) and Diagram 6.1(b). Compare

- (i) the thickness of the copper wire

..... [1 mark]

- (ii) the size of swing angle of the copper wire

..... [1 mark]

- (iii) the force that acted on the copper wire

..... [1 mark]

(c) Based on the answer in 6(b), state the relationship between the force acted on the copper wire and

(i) the thickness of the copper wire

.....
[1 mark]

(ii) size of the swing angle of copper wire

.....
[1 mark]

(d) The pole of the magnet bar in Diagram 6.1(b) is reversed. What happens to the swing of the copper wire?

.....
[1 mark]

(e) The copper wire in Diagram 6.1(b) is then replaced with a coil as shown in Diagram 6.2. When the switch is on, the coil rotates in one direction.

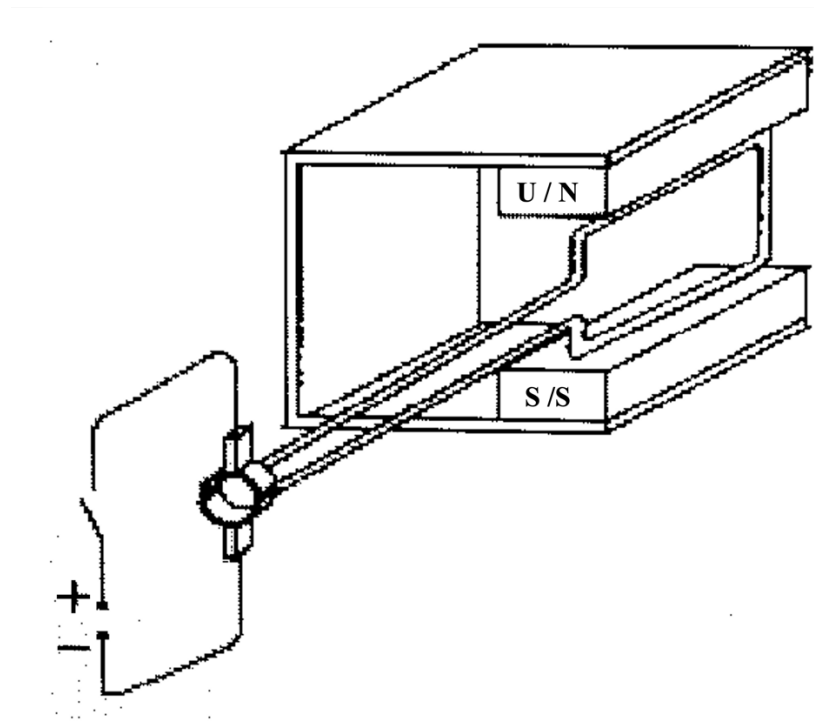

(i) In Diagram 6.2, mark the direction of electric current in the coil.

[1 mark]

(ii) State the direction of rotation of the coil.

.....
[1 mark]

TOTAL 9 marks

SPM 2022

- 9 Rajah 9.1 menunjukkan sebatang magnet bar digerakkan mendekati satu solenoid. Pesongan galvanometer dapat diterangkan berdasarkan konsep aruhan electromagnet. Diagram 9.1 shows a bar magnet is moved closer to a solenoid. The deflection of galvanometer can be explained based on concept of electromagnet induction.

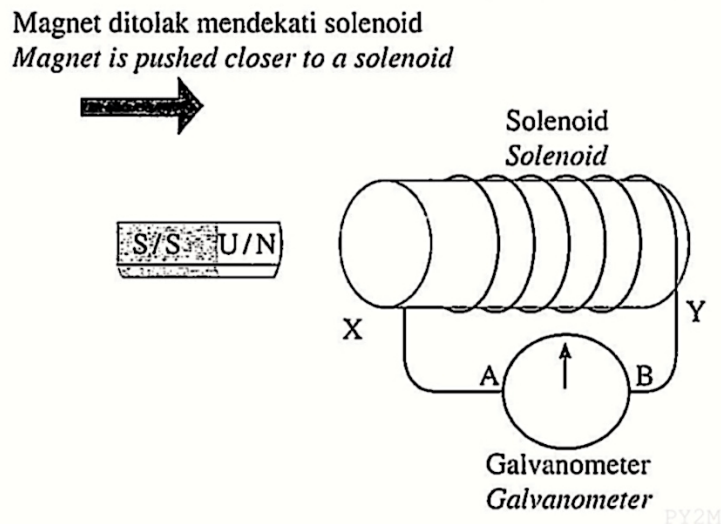

Rajah 9.1 / Diagram 9.1

- (a) Apakah maksud aruhan electromagnet?
What is meant by electromagnetic induction? [1 mark]
- (b) Berdasarkan Rajah 9.1,
Based on Diagram 9.1,
- (i) Nyatakan kekutuban di X dan Y.
State the polarity at X and Y. [2 marks]
- (ii) Tentukan arah arus yang mengalir melalui galvanometer dan nyatakan pesongan galvanometer.
Determine the direction of current that flows through galvanometer and state the deflection of the galvanometer. [2 marks]
- (iii) Terangkan jawapan anda untuk 9(b)(ii).
Explain your answer for 9(b)(ii). [1 mark]
- (c) Berdasarkan konsep aruhan elektromagnet, terangkan bagaimana arus aruhan boleh terhasil dalam solenoid.
Based on the concept of electromagnetic induction, explain how an induced current can be produced in a solenoid. [4 marks]

- (d) Rajah 9.2 menunjukkan sebuah periuk dan dapur aruahn.
Diagram 9.2, shows a pot and an induction cooker.

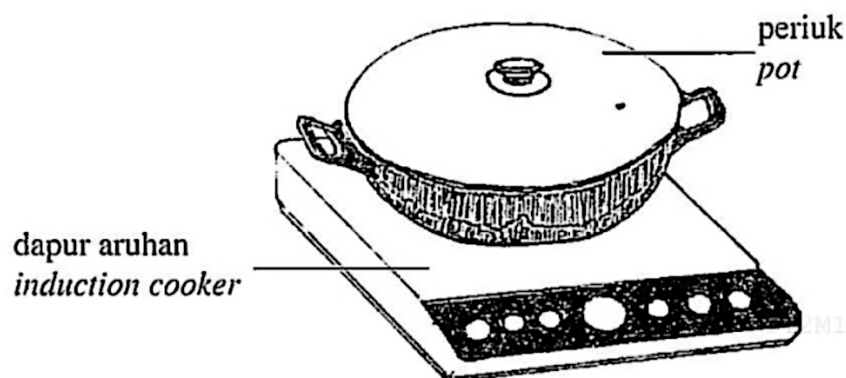

Rajah 9.2 / Diagram 9.2

Anda dikehendaki menyiasat ciri-ciri bagi sebuah dapur aruahn seperti yang ditunjukkan dalam Jadual 2.

You are required to investigate the characteristics of an induction cooker as shown in Table 2.

Dapur aruahn <i>Induction cooker</i>	Jenis bekalan kuasa <i>Type of power supply</i>	Bahan untuk permukaan dapur <i>Material for the surface of cooker</i>	Bahan untuk dasar periuk <i>Material for the base of the pot</i>	Jenis gegelung elektromagnet <i>Type of electromagnetic coil</i>
J	arus terus <i>direct current</i>	Keluli <i>Steel</i>	Besi <i>Iron</i>	Kuprum <i>Cooper</i>
K	arus terus <i>direct current</i>	Seramik <i>Ceramic</i>	Tanah liat <i>Clay</i>	Nikrom <i>Nichrome</i>
L	arus ulang alik <i>alternating current</i>	Seramik <i>Ceramic</i>	Besi <i>Iron</i>	Kuprum <i>Cooper</i>
M	arus ulang alik <i>alternating current</i>	Keluli <i>Steel</i>	Tanah liat <i>Clay</i>	Nikrom <i>Nichrome</i>

Jadual 2 / Table 2

Terangkan kesesuaian setiap ciri dapur aruahn. Tentukan dapur aruahn yang paling berkesan untuk digunakan bagi memasak makanan dengan lebih cekap dan menjimatkan.
Explain the suitability of each characteristic of induction cooker. Determine the most effective induction cooker to be used to cook food more effectively and economically.

[10 marks]

TOTAL 20 marks

- 6 Rajah 6.1 menunjukkan satu konduktor pembawa arus yang diletakkan antara dua magnet bar. Satu medan lastik terhasil.
 Diagram 6.1 shows a current carrying conductor which is placed between two bar magnets. A catapult field is produced.

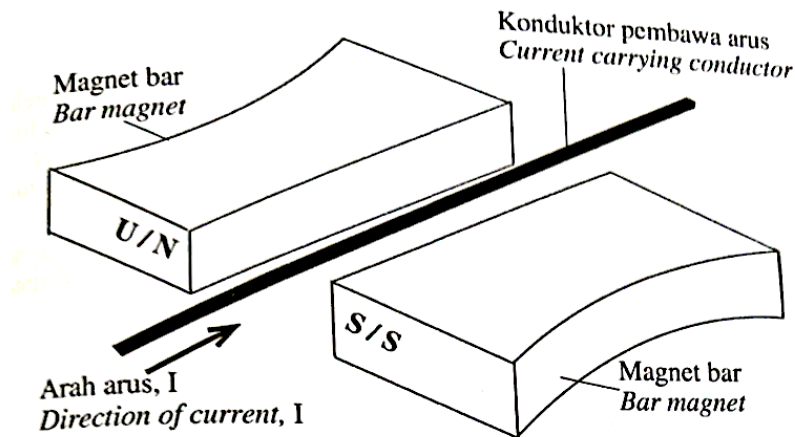

Rajah 6.1 / Diagram 6.1

- (a) (i) Tandakan arah daya pada konduktor pembawa arus dalam Rajah 6.1.
 Mark the direction of force on the current carrying conductor in Diagram 6.1.
- [1 markah / mark]
- (ii) Takrifkan medan lastik.
 Define catapult field.

[1 markah / mark]

- (b) Rajah 6.2(a) dan Rajah 6.2(b) menunjukkan suatu eksperimen ringkas electromagnet.
 Diagram 6.2(a) and Diagram 6.2(b) show a simple experiment of electromagnet.

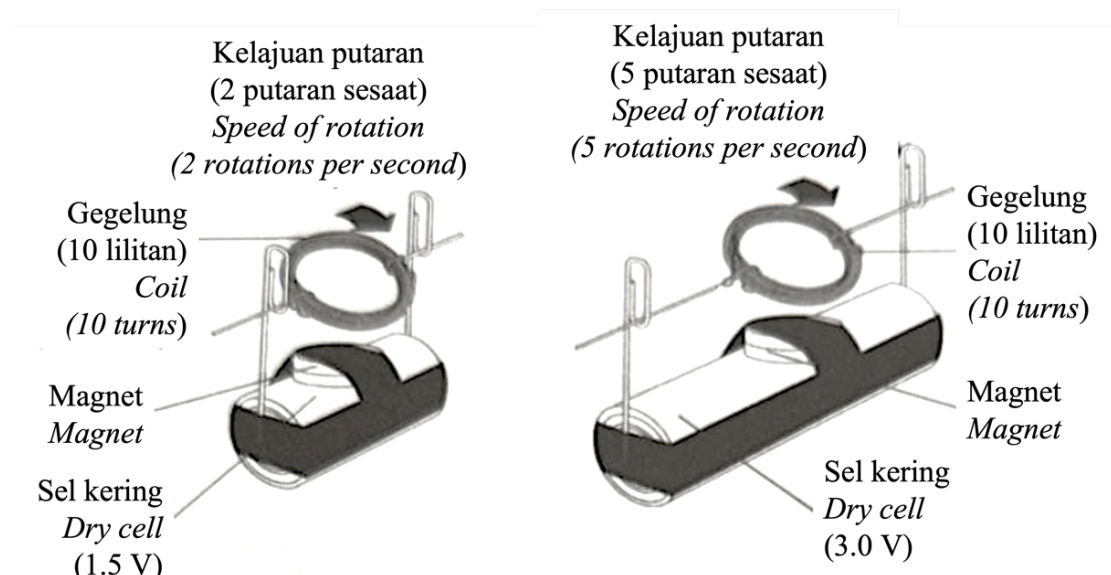

Rajah 6.2(a) / Diagram 6.2(a)

Rajah 6.2(b) / Diagram 6.2(b)

Perhatikan Rajah 6.2(a) dan Rajah 6.2(b). Bandingkan,
Observe Diagram 6.2(a) and Diagram 6.2(b). Compare,

- (i) bilangan lilitan gegelung
the number of turns of coils

.....
[1 markah / mark]

- (ii) beza keupayaan
the potential difference

.....
[1 markah / mark]

- (iii) kelajuan putaran gegelung
the speed of rotation of coil

.....
[1 markah / mark]

- (c) Berdasarkan jawapan anda di 6(b)(i), 6(b)(ii) dan 6(b)(iii), nyatakan hubungan antara
Based on your answer in 6(b)(i), 6(b)(ii) and 6(b)(iii), state the relationship between

- (i) beza keupayaan dengan kelajuan putaran gegelung
the potential difference and the speed of rotation of coil

.....
[1 markah / mark]

- (ii) beza keupayaan dengan daya
the potential difference and the force

.....
[1 markah / mark]

- (d) Sel kering dalam Rajah 6.2(a) digantikan dengan bekalan kuasa arus ulang alik
dengan frekuensi 50 Hz.

Apakah yang akan berlaku kepada putaran gegelung?

Beri **satu** sebab bagi jawapan anda.

*The dry cell in Diagram 6.2(a) is replaced with an alternating current power supply
with the frequency of 50 Hz.*

What will happen to the rotation of the coil?

*Give **one** reason for your answer.*

.....
.....
[2 markah / marks]

TOTAL 9 marks

SPM 2024

- 5 Rajah 4.1 dan Rajah 4.2 menunjukkan dua magnet bar beroda yang serupa. Kedua-dua magnet bar itu dilepaskan dari kedudukan R dan bergerak di sepanjang landasan yang berbeza kecondongan.

Diagrams 4.1 and Diagram 4.2 show two identical wheeled bar magnets. Both bar magnets are released from position R and moving along the runways with different inclinations.

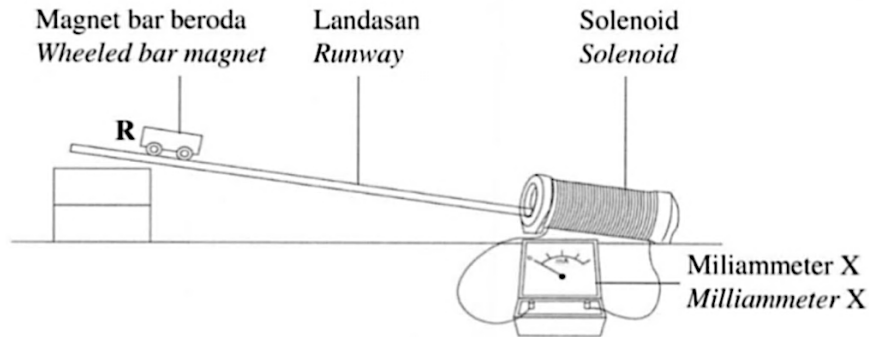

Rajah 4.1 / Diagram 4.1

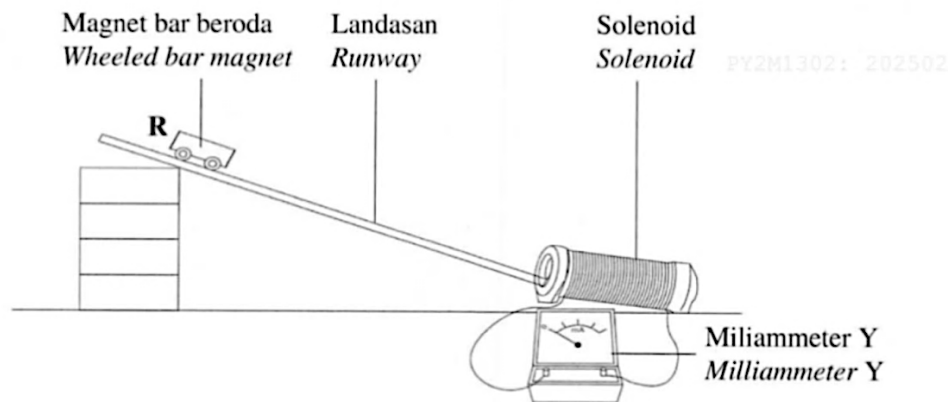

Rajah 4.2 / Diagram 4.2

Apabila magnet bar memasuki solenoid, penunjuk miliammeter terpesong seperti ditunjukkan dalam Rajah 4.3.

As the bar magnets enter the solenoids, the pointers of the milliammeters are deflected as shown in Diagram 4.3.

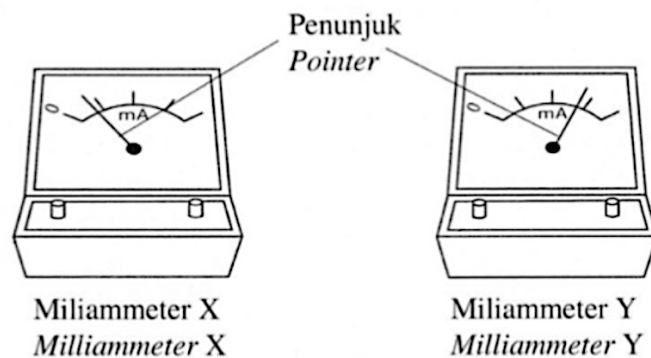

Rajah 4.3 / Diagram 4.3

- (a) Nyatakan konsep fizik yang menyebabkan penunjuk miliammeter terpesong.
State the physics concept that causes the milliammeter pointer to deflect.

.....
[1 markah / mark]

- (b) Berdasarkan Rajah 4.1 dan Rajah 4.2, bandingkan
Based on Diagrams 4.1 and 4.2, compare

- (i) ketinggian magnet bar dilepaskan
the heights that the bar magnets are released

.....
[1 markah / mark]

- (ii) kelajuan magnet bar
the speeds of the bar magnets

.....
[1 markah / mark]

- (iii) arus aruhan yang terhasil apabila magnet bar memasuki solenoid.
the induced currents that are produced when the bar magnets enter the solenoid.

.....
[1 markah / mark]

- (c) Berdasarkan jawapan di 5(b), deduksikan hubungan antara
Based on the answer in 5(b), deduce the relationship between

- (i) ketinggian magnet bar dilepaskan dengan laju magnet bar
the height of the bar magnet is released and the speed of the bar magnet

.....
[1 markah / mark]

- (ii) laju magnet bar dengan arus aruhan.
the speed of the bar magnet and the induced current.

.....
[1 markah / mark]

- (d) Apabila magnet bar memasuki solenoid, magnet bar itu akan mengalami satu daya tolakan dari solenoid.
Terangkan bagaimana daya tolakan itu dihasilkan.
When the bar magnet enters the solenoid, the bar magnet will experience a repulsive force from the solenoid.
Explain how the repulsive force is produced.

.....
[1 markah / mark]

- (e) Satu magnet bar berjisim 0.04 kg bergerak memasuki solenoid dengan pecutan 0.05 ms^{-2} . Daya tujah ke hadapan yang bertindak ke atas magnet bar ialah 0.3 N.
Hitung daya tolakan yang bertindak ke atas magnet bar tersebut.
A bar magnet of mass 0.04 kg moves into the solenoid with an acceleration of 0.05 ms^{-2} . The forward thrust force acting on the bar magnet is 0.3 N.
Calculate the repulsive force acting on the bar magnet.

[2 markah / marks]

TOTAL 9 marks

F5 BAB 5: ELEKTRONIK

SPM 2021 (SET 1)

- 4 Diagram 4 shows a transistor circuit that consist of light dependent resistor (LDR). When the LDR detects light, potential difference of LDR is 1.2 V.

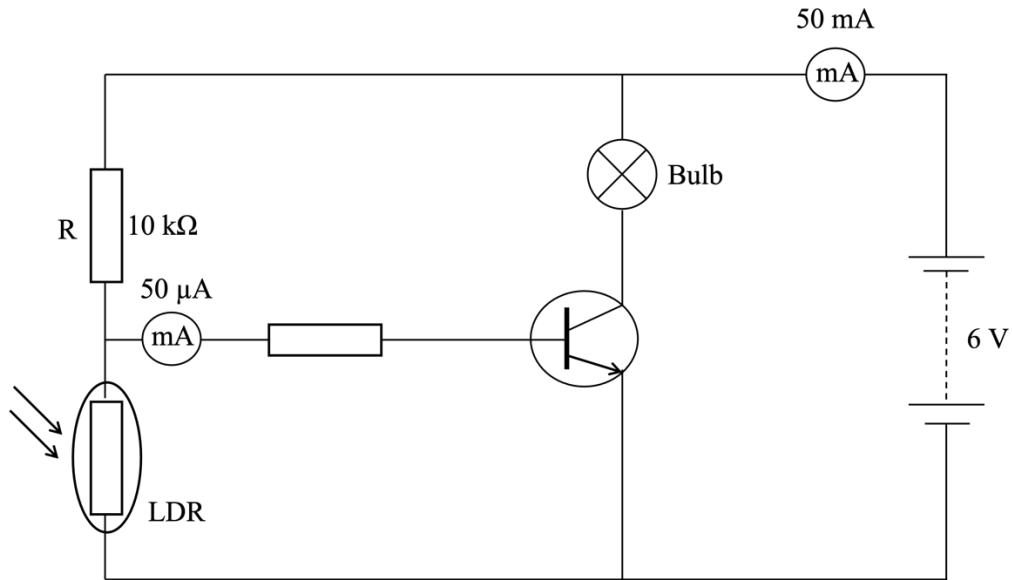

Diagram 4

- (a) Based on Diagram 4,
(i) State the function of the transistor.

..... [1 mark]

- (ii) Calculate the resistance of LDR.

[3 marks]

(iii) Calculate the amplification factor, β .

[2 marks]

(b) Explain how the bulb in Diagram 4 lights up when the surrounding is dark?

.....

.....

.....

[3 marks]

TOTAL 9 marks

SPM 2021 (SET 2)

- 3 Rajah 3.1 menunjukkan rektifier tetimbang yang terdiri daripada empat diod K, L, M dan N dan satu perintang R.

Diagram 3.1 shows a bridge rectifier consist of four diodes K, L, M and N and a resistor, R.

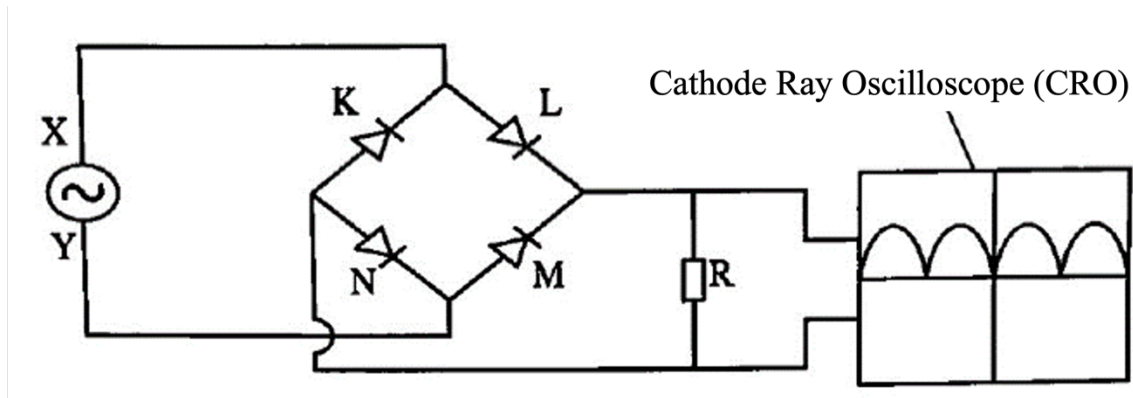

Diagram 3.1

- (a) Berdasarkan Rajah 3,
Based on Diagram 3,

- (i) Namakan jenis rektifikasi.
Name the type of rectification.

.....
[1 mark]

- (ii) Lengkapkan arah pengaliran arus yang melalui diod-diod K, L, M dan N dan perintang, R.

Complete the direction of current flow passing through diodes K, L, M and N and the resistor, R.

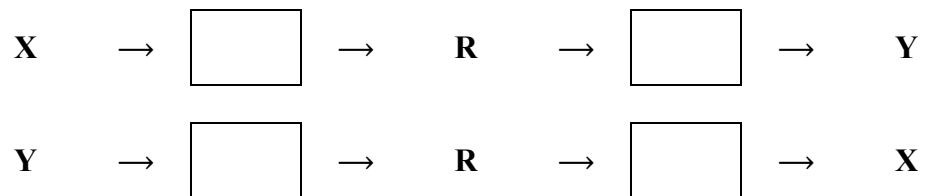

[2 marks]

(b) Diode K dalam Rajah 3 telah rosak.
The K diode in Diagram 3 is faulty.

(i) Lakarkan surihan output pada skrin OSK pada Rajah 3.2.
Sketch the output trace on the CRO screen on Diagram 3.2.



Diagram 3.2

[2 marks]

(ii) Terangkan jawapan anda dalam 3(b)(i).
Explain your answer in 3(b)(i).

.....

[1 mark]

TOTAL 6 marks

- 6 Rajah 6.1 dan Rajah 6.2 menunjukkan dua litar elektrik yang mengandungi diod semikonduktor.
Diagram 6.1 and Diagram 6.2 show two electrical circuits consist of semiconductor diode.

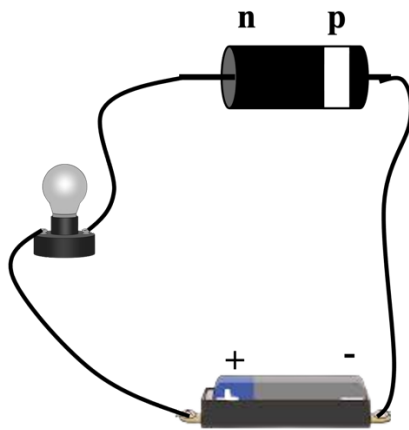

Diagram 6.1

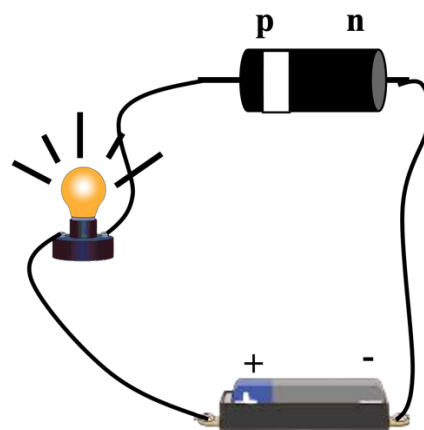

Diagram 6.2

- (a) Apakah yang dimaksudkan dengan semikonduktor?
What is the meaning of semiconductor?

..... [1 mark]

- (b) Menggunakan Rajah 6.1 dan Rajah 6.2, bandingkan
Using Diagram 6.1 and Diagram 6.2, compare

- (i) Nyalaan mentol
The bulb lighting

..... [1 mark]

- (ii) Pengaliran arus dalam litar
Current flows in the circuit

..... [1 mark]

- (iii) Cara sambungan diod semikonduktor ke terminal sel kering.
Way of connection of semiconductor diode to dry cell terminals.

..... [1 mark]

- (c) (i) Hubungkan pengaliran arus dengan cara sambungan diod semikonduktor ke terminal sel kering.
Relate the current flows with the way of connection of semiconductor diode to dry cell terminals.

.....
 [1 mark]

- (ii) Berdasarkan jawapan anda dalam 6(c)(i), nyatakan satu fungsi diod semikonduktor.
Based on your answer in 6(c)(i), state one function of semiconductor diode.

.....
 [1 mark]

- (d) Rajah 6.3 menunjukkan sebuah litar rektifikasi gelombang dan surihan pada skrin osiloskop sinar katod bagi arus input dan arus output selepas melalui diod semikonduktor.
Diagram 6.3 shows a wave rectification circuit and the tracing of cathode ray oscilloscope screen of input current and output current after passing through the semiconductor diode.

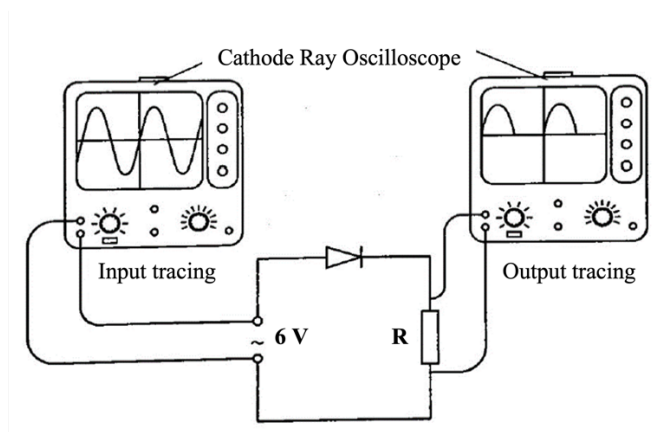

Diagram 6.3

- (i) Berdasarkan Rajah 6.3, mengapakah bentuk gelombang surihan output pada skrin osiloskop sinar katod berubah selepas melalui diod?
Based on Diagram 6.3, why the shape of tracing output wave on the cathode ray oscilloscope screen changes after passing through the diode?

.....
 [1 mark]

- (ii) Jelaskan bagaimana untuk menghasilkan arus mantap pada perintang R dalam Rajah 6.3.
Explain how to produce steady current at resistor R in diagram 6.3.

.....
 [2 marks]

TOTAL 9 marks

SPM 2022

- 8 Rajah 8.1 menunjukkan satu litar rektifikasi. Osiloskop Sinar Katod (OSK) memaparkan surihan arus yang melalui perintang R.
 Diagram 8.1 shows a rectification circuit. The Cathode Ray Oscilloscope (CRO) displays the tracing of current flow through resistor, R.

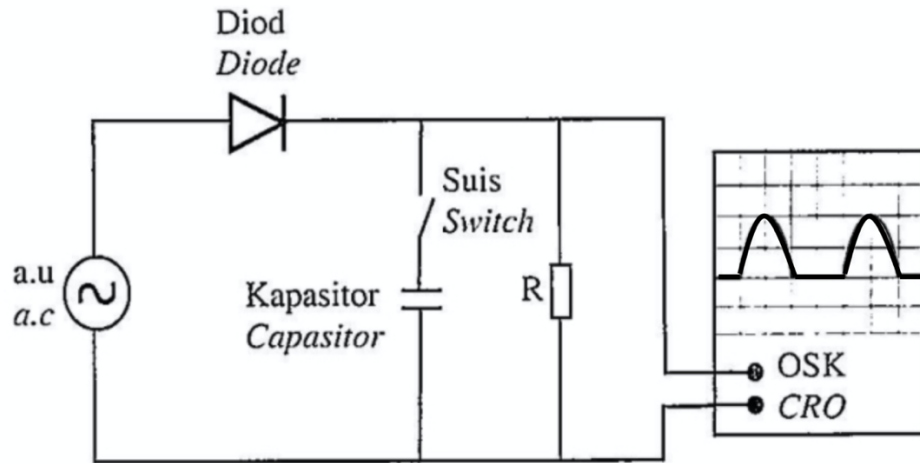

Rajah 8.1 / Diagram 8.1

- (a) Namakan jenis rektifikasi yang ditunjukkan dalam Rajah 8.1.
 Name the type of rectification shown in Diagram 8.1.
-
- [1 mark]
- (b) Suis dalam litar rektifikasi dihidupkan. Jelaskan bagaimana kapasitor dapat mengubah surihan arus.
 The switch in the circuit is turned on. Explain how the capacitor can change the tracing of current.
-
-
- [2 marks]
- (c) Rajah 8.2 menunjukkan litar elektronik bagi unit pengadaptasi arus ulang-alik (a.u).
 Diagram 8.2 shows the electronic circuit of an adapter unit of alternating current (a.c).

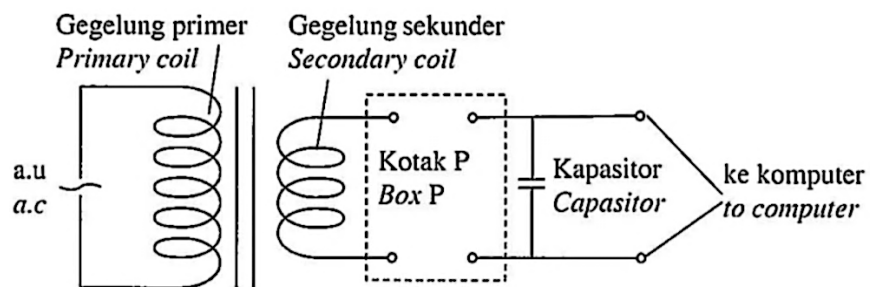

Rajah 8.2 / Diagram 8.2

Cadangkan bagaimana unit pengadaptasi arus ulang-alik (a.u) yang digunakan untuk mengecas computer dapat mengekalkan arus yang seragam berdasarkan aspek-aspek yang berikut:

Suggest how an adapter unit of alternating current (a.c) that is used to charge a computer can maintain uniform current based on the following aspects:

- (i) Bilangan diod yang digunakan dalam Kotak P.
Number of diodes used in the Box P.

.....
[1 mark]

Sebab
Reason

.....
[1 mark]

- (ii) Magnitud bagi kapasitans kapasitor.
The magnitude of capacitance of capasitor.

.....
[1 mark]

Sebab
Reason

.....
[1 mark]

- (d) Berdasarkan Rajah 8.2, transformer dalam unit pengadaptasi arus ulang-alik (a.u) menukar 240 V arus ulang-alik kepada 12 V arus terus (a.t).
Hitung nisbah gegelung primer kepada gegelung sekunder.
*Based on Diagram 8.2, the transformer in a adapter unit of alternating current (a.c) converts 240 V alternating current to 12 V direct current (dc).
Calculate the ratio of primary coil to secondary coil.*

[2 marks]

TOTAL 9 marks

SPM 2023

- 4 Rajah 4 menunjukkan suatu litar bertransistor yang berfungsi sebagai suis automatic.
Diagram 4 shows a transistor circuit that functions as an automatic switch.

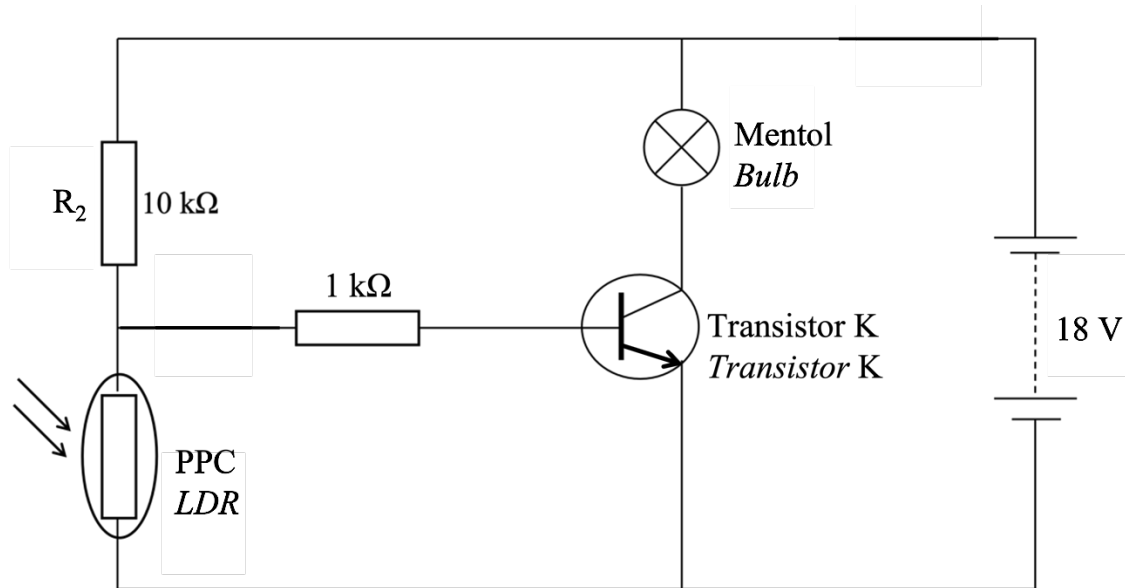

Rajah 4 / Diagram 4

- (a) Namakan jenis transistor K.
Name the type of transistor K.

.....
[1 markah / mark]

- (b) Terangkan bagaimana mentol dalam Rajah 4 boleh menyala dalam keadaan gelap.
Explain how the bulb in Diagram 4 lights up in the dark.

.....
.....
.....

[3 markah / marks]

- (c) Rintangan bagi perintang peka cahaya (PPC) dalam keadaan gelap ialah $50\text{ k}\Omega$.
The resistance of light dependant resistor (LDR) in the dark is $50\text{ k}\Omega$.

Berdasarkan Rajah 4, hitung,
Based on Diagram 4, calculate,

- (i) voltan merentasi PPC
the voltage across the LDR

[3 markah / marks]

- (ii) arus yang mengalir melalui PPC.
the current flowing through the LDR.

[2 markah / marks]

TOTAL 9 marks

- 10 Rajah 9.1 menunjukkan sebuah tiub sinar katod. Elektron dibebaskan dari katod melalui proses pancaran termion, kemudian dipecutkan ke arah anod.
Diagram 9.1 shows a cathode ray tube. Electrons are released from the cathode through the process of thermionic emission, then accelerated towards the anode.

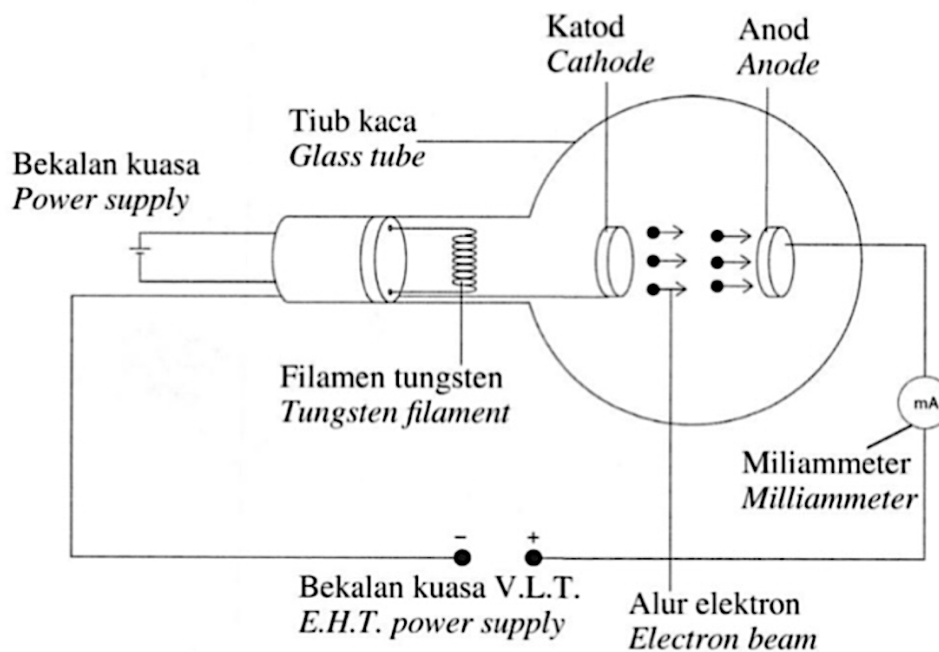

Rajah 9.1 / Diagram 9.1

- (a) Nyatakan satu fungsi miliammeter.
State one function of the milliammeter. [1 markah / mark]
- (b) Diberi bekalan kuasa V.L.T. dalam Rajah 9.1 adalah 6 000 V,
 [Jisim elektron, $m = 9.11 \times 10^{-31}$ kg, Cas satu elektron, $e = 1.6 \times 10^{-19}$ C]
Given that the E.H.T. power supply in Diagram 9.1 is 6 000 V,
 [Mass of electron, $m = 9.11 \times 10^{-31}$ kg, Charge of one electron, $e = 1.6 \times 10^{-19}$ C]

Hitung,
Calculate,

- (i) tenaga kinetik bagi satu elektron yang dibebaskan dari katod
kinetic energy of one electron that is released from the cathode [3 markah / marks]
- (ii) halaju maksimum elektron
maximum velocity of the electron [2 markah / marks]

- (c) Rajah 9.2 menunjukkan bayang-bayang palang Maltese yang terbentuk pada skrin berpendarflour apabila satu magnet diletakkan mendekati tiub palang Maltese.
Diagram 9.2 shows the shadow of a Maltese cross formed on a fluorescent screen when a magnet is placed close to a Maltese cross tube.

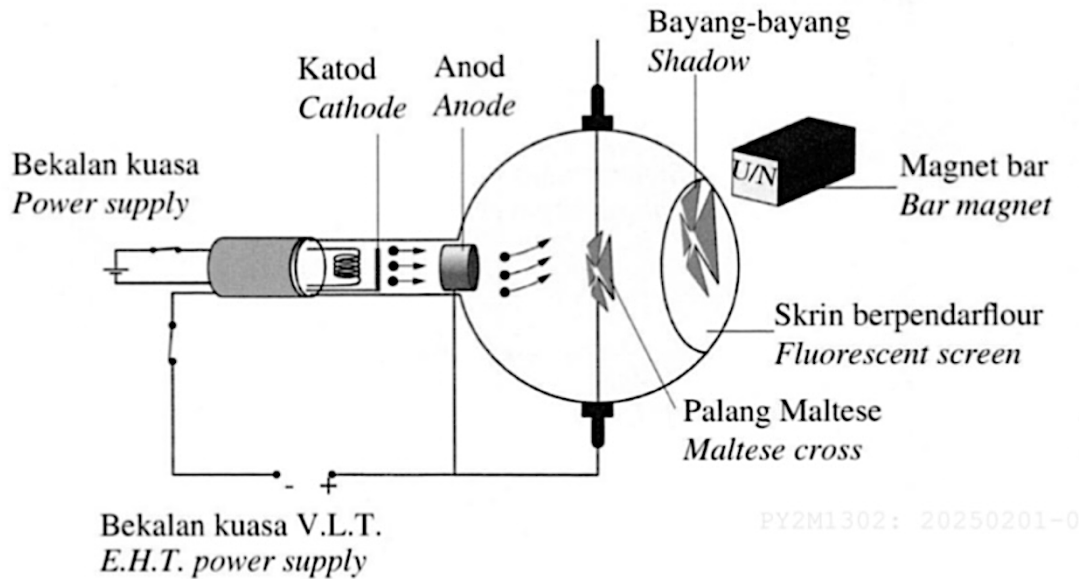

Rajah 9.2 / Diagram 9.2

Berdasarkan Rajah 9.2, terangkan bagaimana
Based on Diagram 9.2, explain how

- (i) pancaran termion berlaku pada katod
thermionic emission occurs at the cathode
[2 markah / marks]

 - (ii) bayang-bayang palang Maltese pada skrin berpendarflour boleh terpesong
the shadow of the Maltese cross on a fluorescent screen can be deflected
[2 markah / marks]
- (d) Tiub sinar katod digunakan dalam mesin pemantau degupan jantung.
 Jadual 4 menunjukkan spesifikasi empat tiub sinar katod, P, Q, R dan S.
*Cathode ray tube is used in the heart rate monitoring machines.
 Table 4 shows the specifications of four cathode ray tubes, P, Q, R and S.*

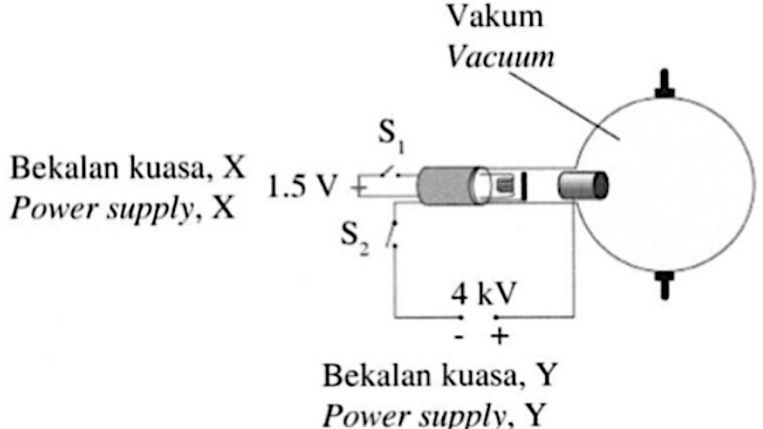
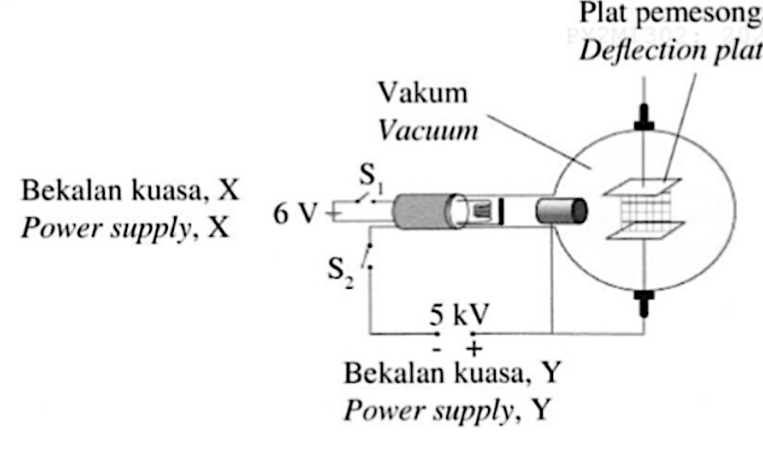
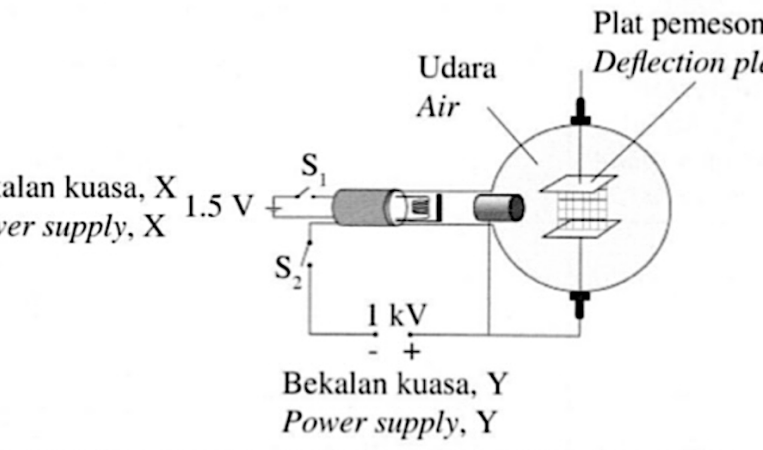
Jenis tiub sinar katod <i>Type of cathode ray tube</i>	Spesifikasi <i>Specification</i>
<p style="text-align: center; font-size: 2em;">P</p>	 <p style="text-align: center;"> Bekalan kuasa, X <i>Power supply, X</i> </p> <p style="text-align: center;"> Bekalan kuasa, Y <i>Power supply, Y</i> </p>
<p style="text-align: center; font-size: 2em;">Q</p>	 <p style="text-align: center;"> Bekalan kuasa, X <i>Power supply, X</i> </p> <p style="text-align: center;"> Bekalan kuasa, Y <i>Power supply, Y</i> </p>
<p style="text-align: center; font-size: 2em;">R</p>	 <p style="text-align: center;"> Bekalan kuasa, X <i>Power supply, X</i> </p> <p style="text-align: center;"> Bekalan kuasa, Y <i>Power supply, Y</i> </p>

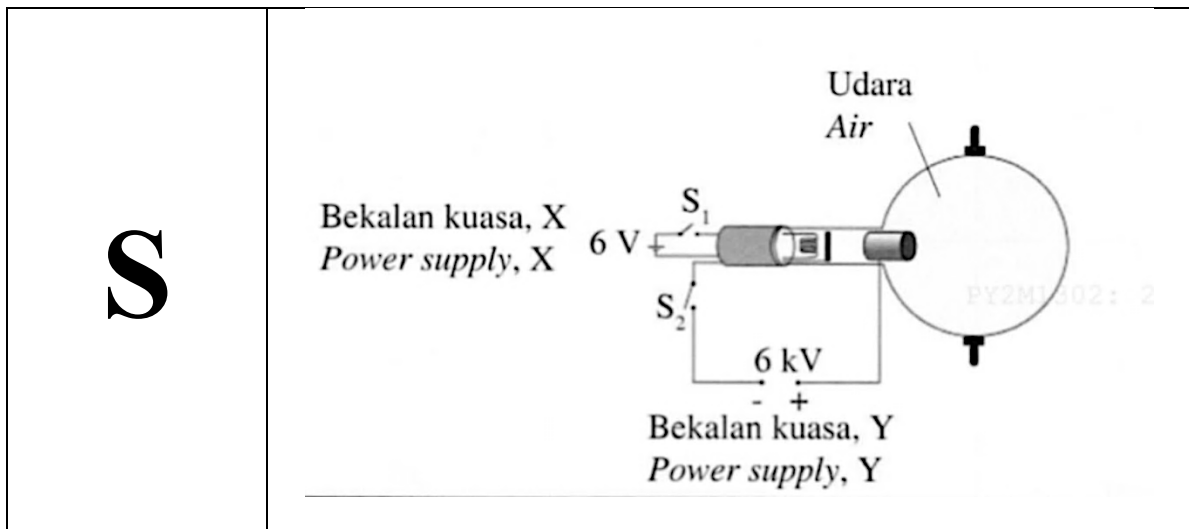

Jadual 4 / Table 4

Berdasarkan spesifikasi dalam Jadual 4, anda dikehendaki menentukan tiub sinar katod yang paling sesuai digunakan dalam mesin pemantau degupan jantung untuk menghasilkan paparan isyarat yang jelas dan tepat.

Terangkan kesesuaian untuk setiap spesifikasi dan tentukan tiub sinar katod yang paling sesuai. Beri sebab-sebab bagi pilihan anda.

Based on the specifications in Table 4, you are required to determine the most suitable cathode ray tube to be used in a heart rate monitor machine to produce a clear and accurate signal display.

Explain the suitability of each specification and determine the most suitable cathode ray tube. Give reasons for your choice.

[10 markah / marks]

TOTAL 20 marks

F5 BAB 6: FIZIK NUKLEAR

SPM 2021 (SET 1)

- 7 Diagram 7 shows a nuclear reactor that generates electrical energy through nuclear fission reaction.

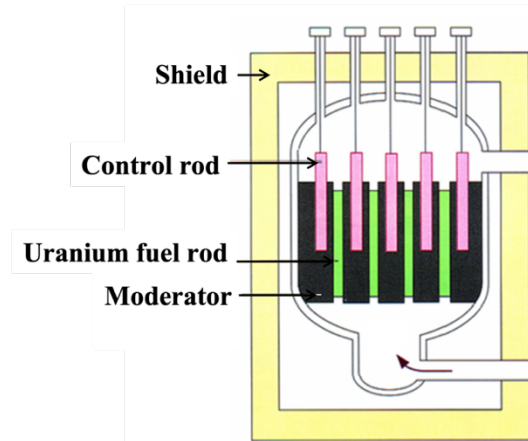
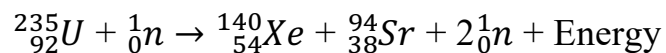

Diagram 7

- (a) What is the meaning of nuclear fission?

.....
[1 mark]

- (b) The nuclear fission reaction occurs in the nuclear reactor in Diagram 7 is represented by the following equation:



The mass defect produced from the nuclear fission reaction of the Uranium fuel is 0.198264 u.
Calculate

- (i) mass defect in the unit of kilogram

[1 mark]

- (ii) Nuclear energy that produced in the nuclear fission reaction.

[2 marks]

- (c) Table 1 show the different characteristics of a few reactor models that will built for generating electrical energy in an industrial area.

Reactor nuclear model	Control rod	Moderator
J	Boron	Cadmium
K	Boron	Graphite
L	Graphite	Boron

Table 1

Based on Table 1, state the suitable characteristics to produce electrical energy with high efficiency.

- (i) Control rod

.....
[1 mark]

Reason

.....
[1 mark]

- (ii) Moderator

.....
[1 mark]

Reason

.....
[1 mark]

- (d) Based on the answer in 7(c)(i) and 7(c)(ii), choose the most suitable nuclear reactor model to generate electrical energy at the industrial area.

.....
[1 mark]

TOTAL 9 marks

SPM 2021 (SET 2)

- 8** Rajah 8 menunjukkan struktur loji janakuasa nuklear. Loji ini menghasilkan tenaga nuklear melalui tindak balas pembelahan nukleus.

Diagram 8 shows a structure of nuclear power plant. The plant produce nuclear energy through nuclear fission reaction.

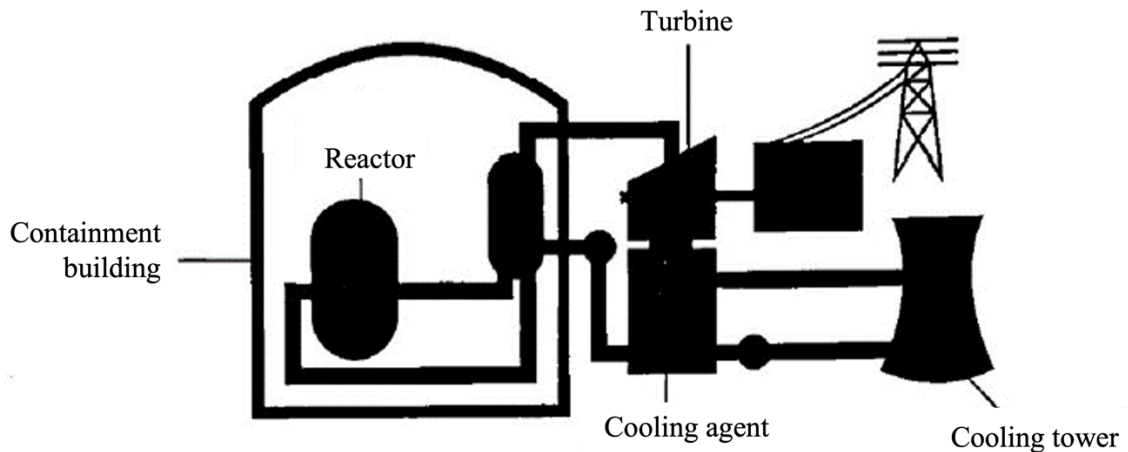

Diagram 8

- (a) Apakah yang dimaksudkan dengan pembelahan nukleus?
What is meant by nuclear fission?

.....
[1 mark]

- (b) Hitung tenaga yang terhasil dari tindak balas pembelahan nukleus jika cacat jisim ialah 3.088×10^{-28} kg.
Calculate the nuclear energy produced from nuclear fission reaction if the mass defect is 3.088×10^{-28} kg.

[2 marks]

- (c) Loji janakuasa nuklear dalam Rajah 8 dicadangkan untuk dibina di Malaysia.
Berikan cadangan berdasarkan aspek-aspek berikut supaya loji dapat beroperasi dengan selamat.

Nuclear power plant in Diagram 8 is proposed to built in Malaysia.

Give suggestions based on the following aspects so that the plant can be operate safely.

- (i) Lokasi loji janakuasa nuklear
Location of the nuclear power plant.

..... [1 mark]

Sebab
Reason

..... [1 mark]

- (ii) Ketebalan dinding bangunan pembendungan.
Thickness of the wall of containment building

..... [1 mark]

Sebab
Reason

..... [1 mark]

- (iii) Bahan agen penyejuk
Material of the cooling agent

..... [1 mark]

Sebab
Reason

..... [1 mark]

TOTAL 9 marks

SPM 2022

- 3 Rajah 3 menunjukkan graf aktiviti melawan masa bagi reputan radioisotope Iodin-131 dengan separuh hayat tertentu.

Diagram 3 shows a graph of activity against time for radioisotope decay of Iodine-131 with a certain half-life.

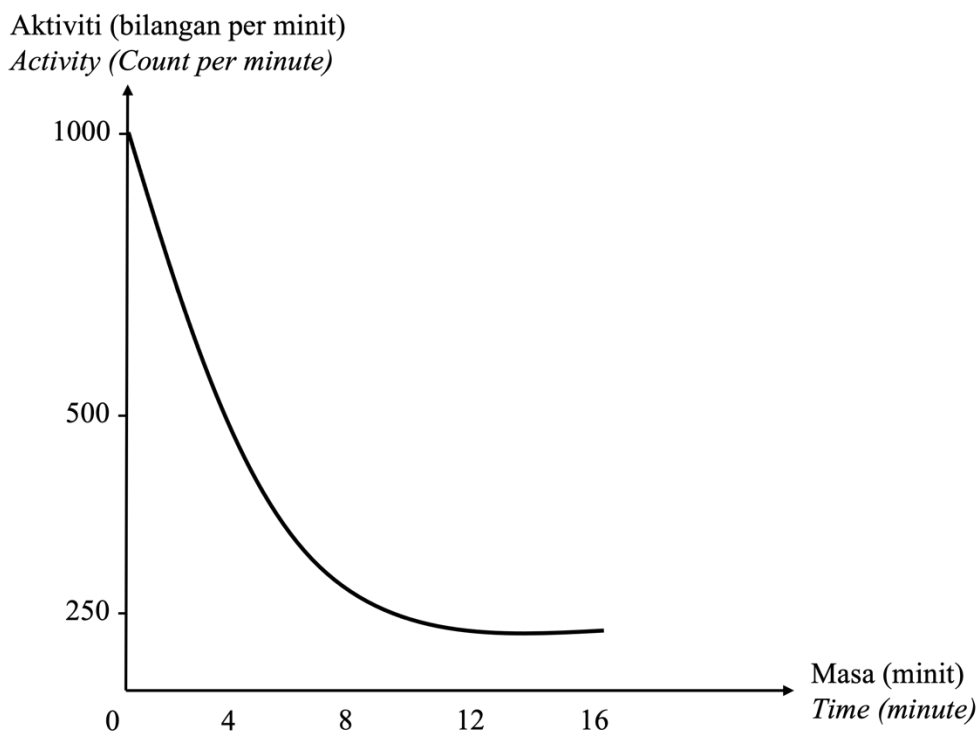

Rajah 3 / Diagram 3

- (a) Apakah maksud separuh hayat?
What is meant by half-life?

.....
[1 mark]

- (b) Berdasarkan Rajah 3, tentukan nilai separuh hayat Iodin-131.
Tunjukkan pada graf bagaimana anda menentukan separuh hayat itu.
*Based on Diagram 3, determine the value of half-life of Iodine-131.
Show on the graph how you determine the half-life.*

Separuh hayat Iodin-131:
Half-life of Iodine-131

[2 marks]

- (c) Tentukan aktiviti selepas empat separuh hayat?
Determine the activity after four half-life?

[2 marks]

- (d) Mengapakah reputan radioisotop tersebut terus berlaku?
Why does the radioisotope decay continues to occur?

.....
[1 mark]

TOTAL 6 marks

SPM 2023

- 11 Rajah 11 menunjukkan graf separuh hayat bagi Radioisotop X dan Radioisotop Y.
Diagram 11 shows the half-life graph for Radioisotope X and Radioisotope Y.

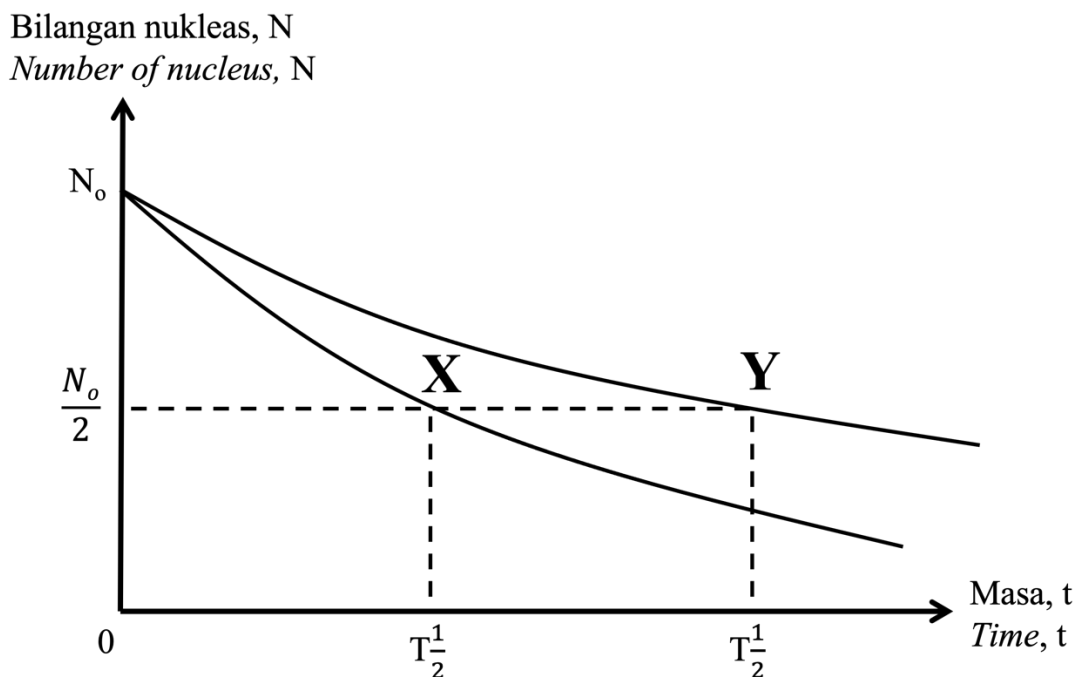

Rajah 11 / *Diagram 11*

- (a) Apakah yang dimaksudkan dengan separuh hayat?
What is meant by half-life?

[1 markah / *mark*]

- (b) Perhatikan Rajah 11, bandingkan bilangan nukleus asal, separuh hayat dan kadar reputan antara Radioisotop X dan Radioisotop Y.
Hubungkaitkan antara bilangan nukleus asal dengan separuh hayat dan seterusnya deduksikan hubungan antara separuh hayat dengan kadar reputan.
Observe Diagram 11, compare the number of original nuclei, half-life and decay rate between Radioisotope X and Radioisotope Y.
Relate the number of original nuclei with the half-life and then deduce the relationship between the half-life and the decay rate.

[5 markah / *marks*]

- (c) Radioisotop Y mengalami pembelahan nukleus dan menghasilkan tenaga nuklear. Terangkan mengapa tenaga nuklear boleh dihasilkan semasa proses pembelahan nucleus.

Radioisotope Y experience nuclear fission and produces nuclear energy.

Explain why nuclear energy can be produced during the of nuclear fission process.

[4 markah / marks]

- (d) Kerajaan bercadang supaya tenaga nuklear digunakan untuk menjana tenaga elektrik bagi menyelesaikan masalah krisis tenaga di kawasan perindustrian.

Anda sebagai ahli sains perlu menjalankan kajian dan membuat cadangan berkaitan aspek struktur reaktor nuklear dan penjana arus elektrik yang sesuai digunakan supaya tenaga nuklear dan tenaga elektrik yang dihasilkan adalah mencukupi dan selamat digunakan.

Nyatakan dan terangkan cadangan anda melibatkan aspek ketebalan dinding reaktor nuklear, jenis radioisotop yang digunakan, keselamatan reaktor nuclear, turbin dan solenoid dalam penjana arus elektrik.

The government proposed that nuclear energy is used to generate electricity to solve the energy crisis problem in industrial areas.

You as a scientist need to conduct a research and make recommendations related to the structural aspects of nuclear reactors and electric current generators that are suitable for use so that the nuclear energy and electricity produced are sufficient and safe to use.

State and explain your proposal involving aspects of nuclear reactor wall thickness, types of radioisotopes used, nuclear reactor safety, turbines and solenoids in electric current generators.

[10 markah / marks]

TOTAL 20 marks

SPM 2024

3 Dalam satu siri reputan radioaktif, Radon-222 mereput menjadi Polonium-218 dengan memancarkan zarah alfa.
In a series of radioactive decays, Radon-222 decays into Polonium-218 by emitting an alpha particle.

- (a) (i) Lengkapkan persamaan reputan Radon-222.
Complete the equation for the decay of Radon-222.

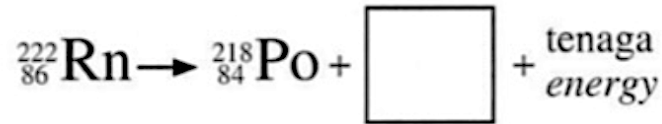

[1 markah / mark]

- (ii) Mengapa reputan radioaktif tersebut berlaku?
Why does the radioactive decay occur?

.....
[1 markah / mark]

(b) Cacat jisim yang berlaku dalam reputan radioaktif tersebut adalah 0.513 u.j.a..
Hitung,
The mass defect occurred in the radioactive decay is 0.513 a.m.u..
Calculate,

- (i) cacat jisim dalam unit kg
mass defect in the unit of kg

[1 markah / mark]

- (ii) tenaga nuklear yang dibebaskan
nuclear energy released

[2 markah / marks]

(c) Nyatakan konsep fizik yang terlibat dalam penghasilan tenaga nuklear daripada cacat jisim.
State the physics concepts involved in the production of nuclear energy from mass defects.

.....
[1 markah / mark]

TOTAL 6 marks

F5 BAB 7: FIZIK KUANTUM

SPM 2021 (SET 1)

- 2 Diagram 2 shows an apparatus to study the effect of photoelectric for zinc metal. The electrons are emitted from the surface of the zinc metal and move towards anode.

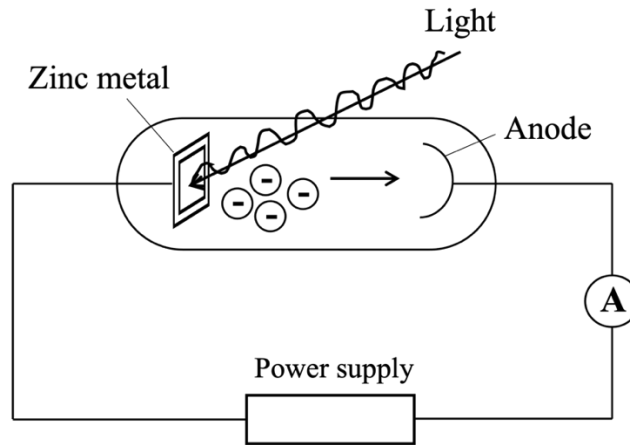

Diagram 2

The light frequency used is 9×10^{14} Hz that exceeds the threshold frequency, f_0 of zinc.

- (a) What is the meaning of threshold frequency, f_0 ?

.....
[1 mark]

- (b) Calculate the work function of metal zinc.

Given work function, $W = hf_0$
[Planck's constant, $h = 6.63 \times 10^{-34}$ J s]

[2 marks]

- (c) The intensity of light that strikes the surface of zinc metal does not affect the kinetic energy of electron.
Explain why.

.....
.....
[2 marks]

TOTAL 5 marks

SPM 2022

- 2 Rajah 2 menunjukkan satu litar sel foto. Katod berbentuk semisilinder disaluti dengan logam peka cahaya. Apabila katod disinari oleh alur cahaya, electron terpancar keluar dari permukaan logam tersebut. Penunjuk milliammeter terpesong.

Diagram 2 shows a photocell circuit. The semi-cylinder cathode is coated with light sensitive metal. When the cathode is illuminated by beam of light, electrons emitted from the metal surface. The milliammeter pointer deflects.

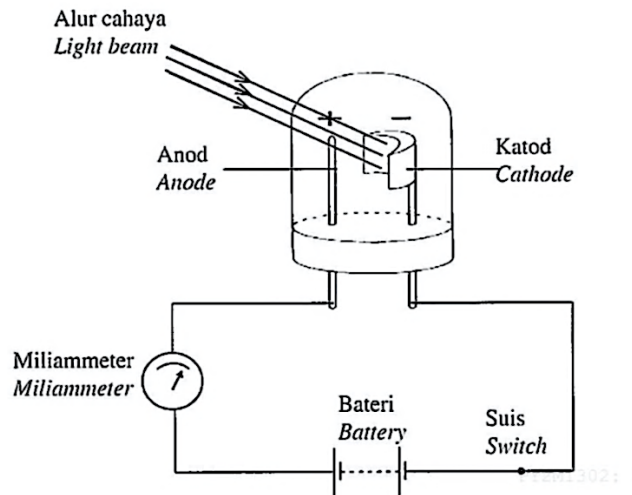

Rajah 2 / Diagram 2

- (a) Namakan fenomena yang menyebabkan electron terpancar keluar dari permukaan logam peka cahaya itu.

Name the phenomenon that cause the electrons to emit from the surface of light sensitive metal..

.....

[1 mark]

- (b) Terangkan bagaimana penunjuk milliammeter terpesong.

Explain how the milliammeter pointer deflects.

.....

.....

[2 marks]

- (c) Frekuensi ambang bagi logam peka cahaya dalam sel foto itu ialah 5.2×10^{14} Hz. Hitung fungsi kerja bagi loga peka cahaya dalam sel foto itu.

The threshold frequency fir the light sensitive metal in the photocell is 5.2×10^{14} Hz. Calculate the work function of the light sensitive metal in the photocell.

[2 marks]

TOTAL 5 marks

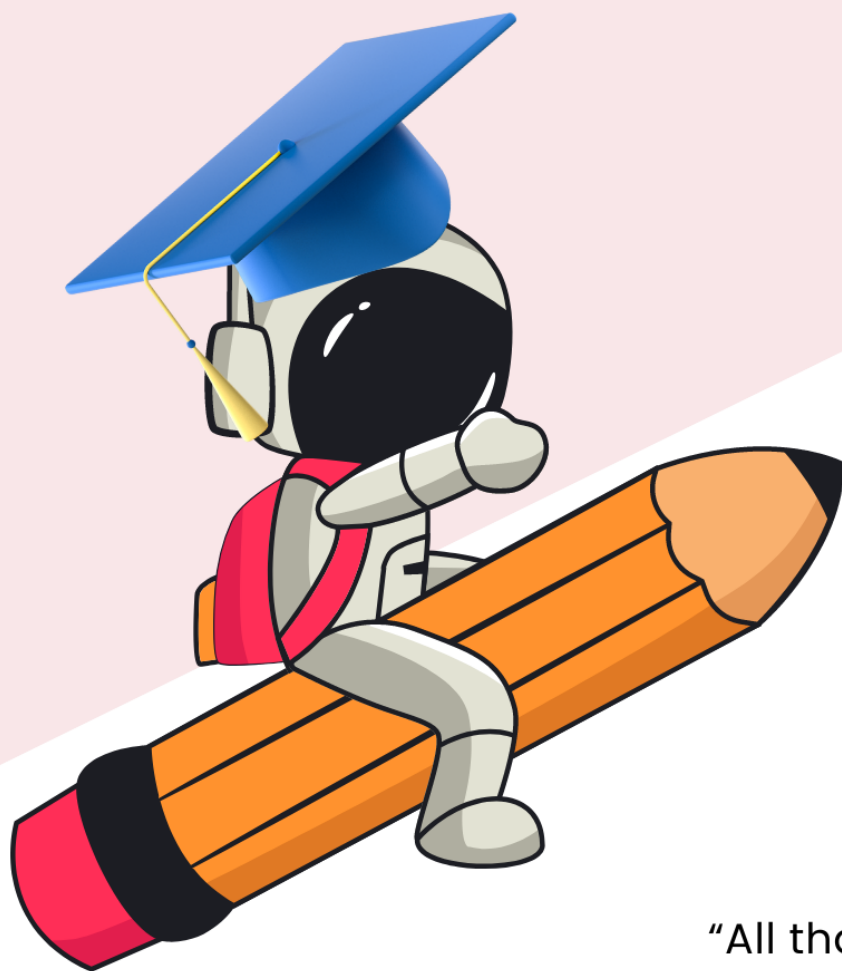

"All that glitters may not
be gold,
but at least it contains
free electrons."
-John Desmond Bernal-